



**NONRESIDENT TRAINING  
COURSE**

**Antennas and Wave  
Propagation**

**DISTRIBUTION STATEMENT A: Approved for public release; distribution is unlimited.**

# CONTENTS

CHAPTER	Page
1. Wave Propagation .....	
2. Antennas .....	
3. Introduction to Transmission and Waveguides .....	
APPENDIX	
I. Glossary .....	AI-1
II. References .....	AII-1
INDEX .....	Index-1

# CHAPTER 1 WAVE

## PROPAGATION

The eyes and ears of a ship or shore station depend on sophisticated, highly computerized electronic systems. The one thing all of these systems have in common is that they lead to and from *antennas*. Ship's operators who must communicate, navigate, and be ready to fight the ship 24 hours a day depend on you to keep these emitters and sensors operational.

In this volume, we will review wave propagation, antenna characteristics, shore-based and shipboard communications antennas, matching networks, antenna tuning, radar antennas, antenna safety, transmission lines, connector installation and weatherproofing, waveguides, and waveguide couplings. When you have completed this chapter, you should be able to discuss the basic principles of wave propagation and the atmosphere's effects on wave propagation.

### THE EARTH'S ATMOSPHERE

While radio waves traveling in free space have little outside influence to affect them, radio waves traveling in the earth's atmosphere have many influences that affect them. We have all experienced problems with radio waves, caused by certain atmospheric conditions complicating what at first seemed to be a relatively simple electronic problem. These problem-causing conditions result from a lack of uniformity in the earth's atmosphere.

Many factors can affect atmospheric conditions, either positively or negatively. Three of these are variations in geographic height, differences in geographic location, and changes in time (day, night, season, year).

To understand wave propagation, you must have at least a basic understanding of the earth's atmosphere. The earth's atmosphere is divided into three separate regions, or layers. They are the *troposphere*, the *stratosphere*, and the *ionosphere*. These layers are illustrated in figure 1-1.

### TROPOSPHERE

Almost all weather phenomena take place in the troposphere. The temperature in this region decreases rapidly with altitude. Clouds form, and there may be a lot of turbulence because of variations in the temperature, pressure, and density. These conditions have a profound effect on the propagation of radio waves, as we will explain later in this chapter.

### STRATOSPHERE

The stratosphere is located between the troposphere and the ionosphere. The temperature throughout this region is almost constant and there is little water vapor present. Because it is a relatively calm region with little or no temperature change, the stratosphere has almost no effect on radio waves.

### IONOSPHERE

This is the most important region of the earth's atmosphere for long distance, point-to-point communications. Because the existence of the ionosphere is directly related to radiation emitted from the sun, the movement of the earth about the sun or changes in the sun's activity will result in variations in the ionosphere. These variations are of two general types:

(1) those that more or less occur in cycles and, therefore, can be predicted with reasonable accuracy; and (2) those that are irregular as a result of abnormal behavior of the sun and, therefore, cannot be predicted. Both regular and irregular variations have important effects on radio-wave propagation. Since irregular variations cannot be predicted, we will concentrate on regular variations.

### Regular Variations

The regular variations can be divided into four main classes: daily, 27-day, seasonal, and 11-year. We will concentrate our discussion on daily variations,

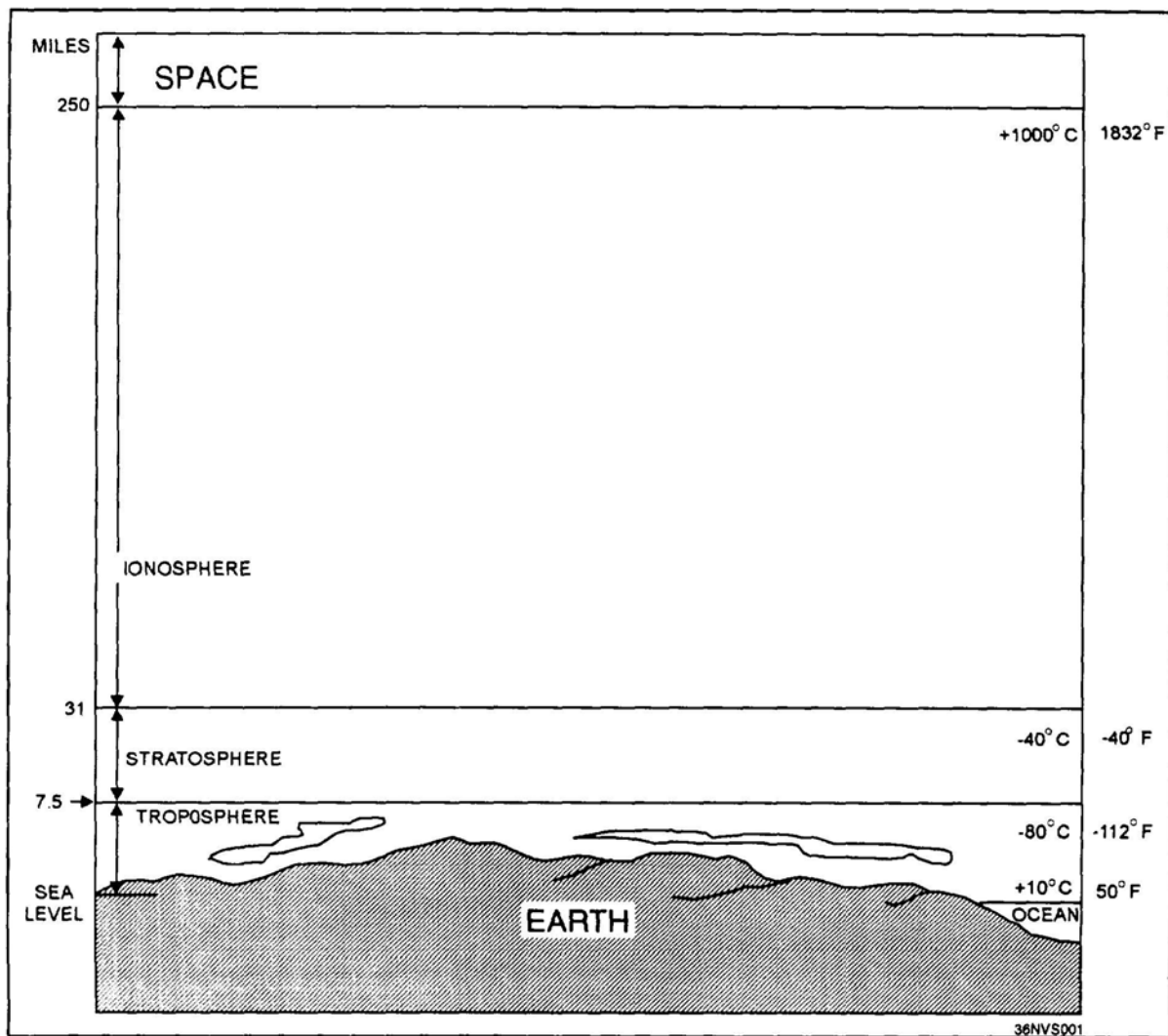

Figure 1.1—Atmospheric layers.

since they have the greatest effect on your job. Daily variations in the ionosphere produce four cloud-like layers of electrically-charged gas atoms called *ions*, which enable radio waves to be propagated great distances around the earth. Ions are formed by a process called *ionization*.

### Ionization

In ionization, high-energy ultraviolet light waves from the sun periodically enter the ionosphere, strike neutral gas atoms, and knock one or more electrons free from each atom. When the electrons are knocked free, the atoms become positively charged (**positive ions**) and remain in space, along with the negatively-charged free electrons. The free electrons absorb some

of the ultraviolet energy that initially set them free and form an ionized layer.

Since the atmosphere is bombarded by ultraviolet waves of differing frequencies, several ionized layers are formed at different altitudes. Ultraviolet waves of higher frequencies penetrate the most, so they produce ionized layers in the lower portion of the ionosphere. Conversely, ultraviolet waves of lower frequencies penetrate the least, so they form layers in the upper regions of the ionosphere.

An important factor in determining the density of these ionized layers is the elevation angle of the sun. Since this angle changes frequently, the height and thickness of the ionized layers vary, depending

on the time of day and the season of the year. Another important factor in determining layer density is known as *recombination*.

### Recombination

Recombination is the reverse process of ionization. It occurs when free electrons and positive ions collide, combine, and return the positive ions to their original neutral state.

Like ionization, the recombination process depends on the time of day. Between early morning and late afternoon, the rate of ionization exceeds the rate of recombination. During this period the ionized layers reach their greatest density and exert maximum influence on radio waves. However, during the late afternoon and early evening, the rate of recombination exceeds the rate of ionization, causing the densities of the ionized layers to decrease. Throughout the night, density continues to decrease, reaching its lowest point just before sunrise. It is important to understand that this ionization and recombination process varies, depending on the ionospheric layer and the time of day. The following paragraphs provide an explanation of the four ionospheric layers.

### Ionospheric Layers

The ionosphere is composed of three distinct layers, designated from lowest level to highest level (**D**, **E**, and **F**) as shown in figure 1-2. In addition, the

**F** layer is divided into two layers, designated **F1** (the lower level) and **F2** (the higher level).

The presence or absence of these layers in the ionosphere and their height above the earth vary with the position of the sun. At high noon, radiation in the ionosphere above a given point is greatest, while at night it is minimum. When the radiation is removed, many of the particles that were ionized recombine. During the time between these two conditions, the position and number of ionized layers within the ionosphere change.

Since the position of the sun varies daily, monthly, and yearly with respect to a specific point on earth, the exact number of layers present is extremely difficult to determine. However, the following general statements about these layers can be made.

**D LAYER.**— The **D** layer ranges from about 30 to 55 miles above the earth. Ionization in the **D** layer is low because less ultraviolet light penetrates to this level. At very low frequencies, the **D** layer and the ground act as a huge waveguide, making communication possible only with large antennas and high-power transmitters. At low and medium frequencies, the **D** layer becomes highly absorptive, which limits the effective daytime communication range to about 200 miles. At frequencies above about 3 MHz, the **D** layer begins to lose its absorptive qualities.

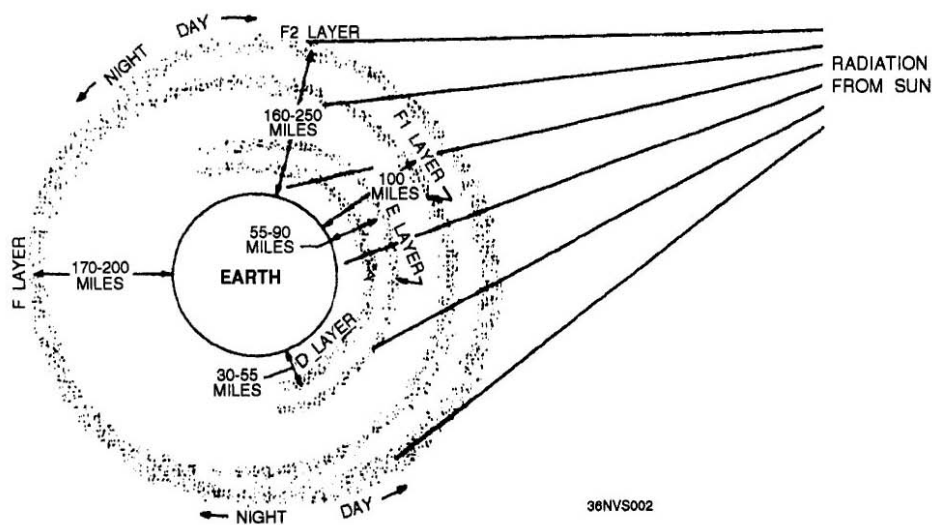

Long-distance communication is possible at frequencies as high as 30 MHz. Waves at frequencies above this range pass through the **D** layer but are attenuated. After sunset, the **D** layer disappears because of the rapid recombination of ions. Low-frequency and medium-frequency long-distance communication becomes possible. This is why **AM** behaves so differently at night. Signals passing through the **D** layer normally are not absorbed but are propagated by the **E** and **F** layers.

**E LAYER.**— The **E** layer ranges from approximately 55 to 90 miles above the earth. The rate of ionospheric recombination in this layer is rather rapid after sunset, causing it to nearly disappear by midnight. The **E** layer permits medium-range communications on the low-frequency through veryhigh-frequency bands. At frequencies above about 150 MHz, radio waves pass through the **E** layer.

Sometimes a solar flare will cause this layer to ionize at night over specific areas. Propagation in this layer during this time is called SPORADIC-E. The range of communication in sporadic-E often exceeds 1000 miles, but the range is not as great as with **F** layer propagation.

**F LAYER.**— The **F** layer exists from about 90 to 240 miles above the earth. During daylight hours, the **F** layer separates into two layers, **F1** and **F2**. During the night, the **F1** layer usually disappears. The **F** layer produces maximum ionization during the afternoon hours, but the effects of the daily cycle are not as pronounced as in the **D** and **E** layers. Atoms in the **F** layer stay ionized for a longer time after sunset, and during maximum sunspot activity, they can stay ionized all night long.

Since the **F** layer is the highest of the ionospheric layers, it also has the longest propagation capability. For horizontal waves, the single-hop **F2** distance can reach 3000 miles. For signals to propagate over greater distances, multiple hops are required.

The **F** layer is responsible for most high-frequency, long-distance communications. The maximum frequency that the **F** layer will return depends on the degree of sunspot activity. During maximum sunspot activity, the **F** layer can return

signals at frequencies as high as 100 MHz. During minimum sunspot activity, the maximum usable frequency can drop to as low as 10 MHz.

## ATMOSPHERIC PROPAGATION

Within the atmosphere, radio waves can be refracted, reflected, and diffracted. In the following paragraphs, we will discuss these propagation characteristics.

### REFRACTION

A radio wave transmitted into ionized layers is always refracted, or bent. This bending of radio waves is called *refraction*. Notice the radio wave shown in figure 1-3, traveling through the earth's atmosphere at a constant speed. As the wave enters the denser layer of charged ions, its upper portion moves faster than its lower portion. The abrupt speed increase of the upper part of the wave causes it to bend back toward the earth. This bending is always toward the propagation medium where the radio wave's velocity is the least.

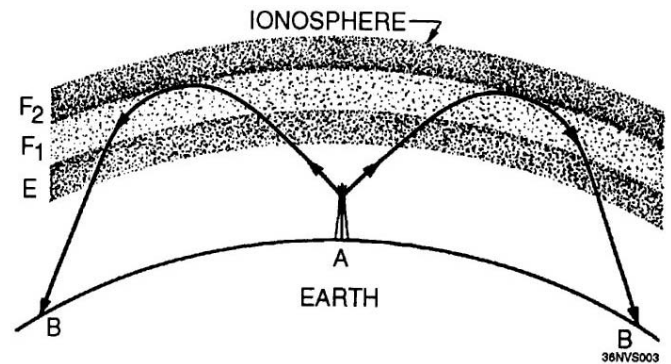

Figure 1-3.—Radio-wave refraction.

The amount of refraction a radio wave undergoes depends on three main factors.

1. The ionization density of the layer
2. The frequency of the radio wave
3. The angle at which the radio wave enters the layer

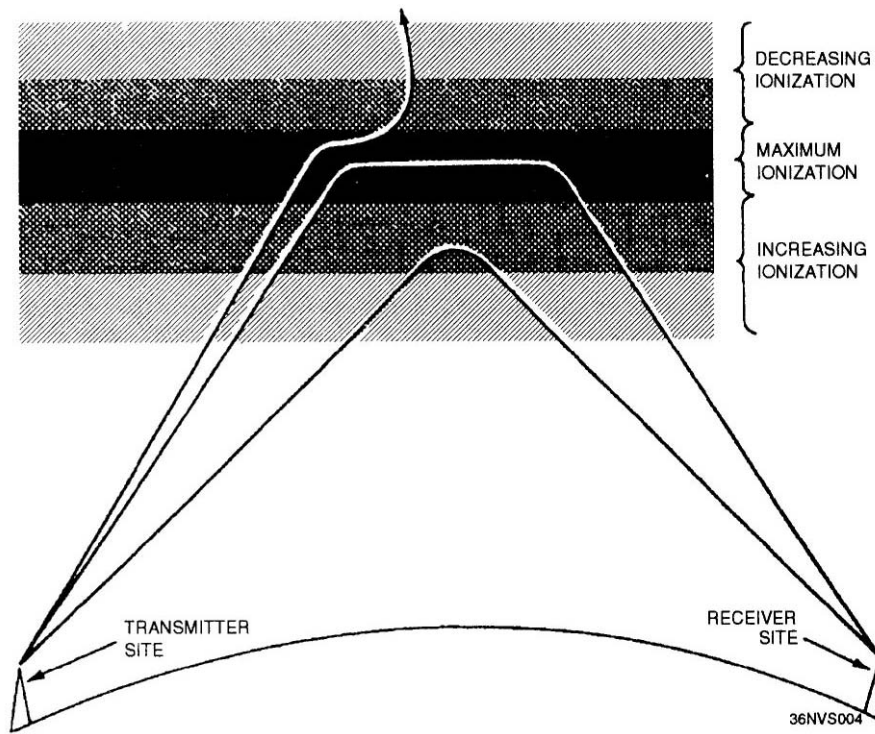

Figure 1-4.—Effects of ionospheric density on radio waves.

### Layer Density

Figure 1-4 shows the relationship between radio waves and ionization density. Each ionized layer has a middle region of relatively dense ionization with less intensity above and below. As a radio wave enters a region of **increasing** ionization, a velocity increase causes it to bend back **toward** the earth. In the highly dense middle region, refraction occurs more slowly because the ionization density is uniform. As the wave enters the upper less dense region, the velocity of the upper part of the wave decreases and the wave is bent away from the earth.

### Frequency

The lower the frequency of a radio wave, the more rapidly the wave is refracted by a given degree of ionization. Figure 1-5 shows three separate waves of differing frequencies entering the ionosphere at the same angle. You can see that the 5-MHz wave is refracted quite sharply, while the 20-MHz wave is refracted less sharply and returns to earth at a greater distance than the 5-MHz wave. Notice that the 100-MHz wave is lost

into space. For any given ionized layer, there is a frequency, called the *escape point*, at which energy transmitted directly upward will escape into space. The maximum frequency just below the escape point is called the **critical frequency**. In this example, the 100-MHz wave's frequency is greater than the critical frequency for that ionized layer.

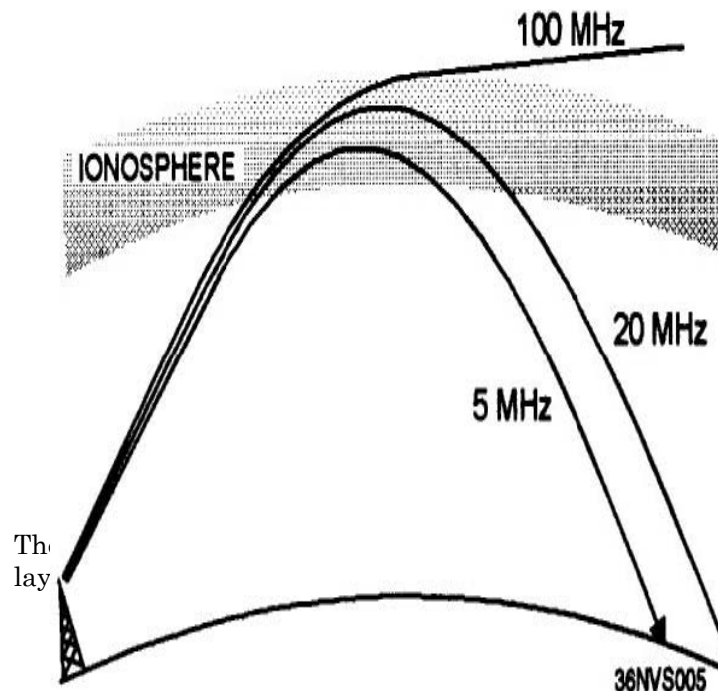

particular layer, it may still be refracted by a higher layer if its frequency is lower than the higher layer's critical frequency.

### Angle of Incidence and Critical Angle

When a radio wave encounters a layer of the ionosphere, that wave is returned to earth at the same angle (roughly) as its *angle of incidence*. Figure 1-6 shows three radio waves of the same frequency entering a layer at different incidence angles. The angle at which wave A strikes the layer is too nearly vertical for the wave to be refracted to earth. However, wave B is refracted back to earth. The angle between wave B and the earth is called the **critical angle**. Any wave, at a given frequency, that leaves the antenna at an incidence angle greater than the critical angle will be lost into space. This is why wave A was not refracted. Wave C leaves the antenna at the smallest angle that will allow it to be refracted and still return to earth. The critical angle for radio waves depends on the layer density and the wavelength of the signal.

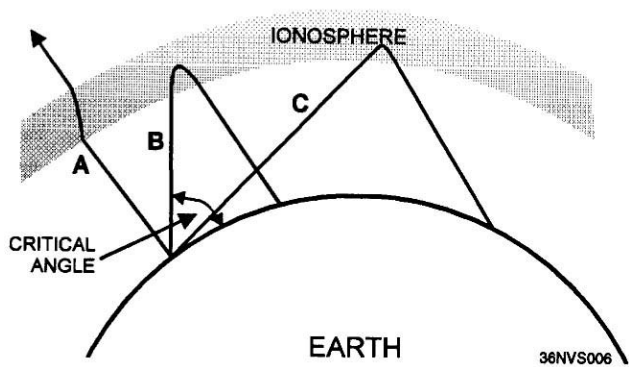

Figure 1-6.—Incidence angles of radio waves.

As the frequency of a radio wave is increased, the critical angle must be reduced for refraction to occur. Notice in figure 1-7 that the 2-MHz wave strikes the ionosphere at the critical angle for that frequency and is refracted. Although the 5-MHz line (broken line) strikes the ionosphere at a less critical angle, it still penetrates the layer and is lost. As the angle is lowered, a critical angle is finally reached for the 5-MHz wave and it is refracted back to earth.

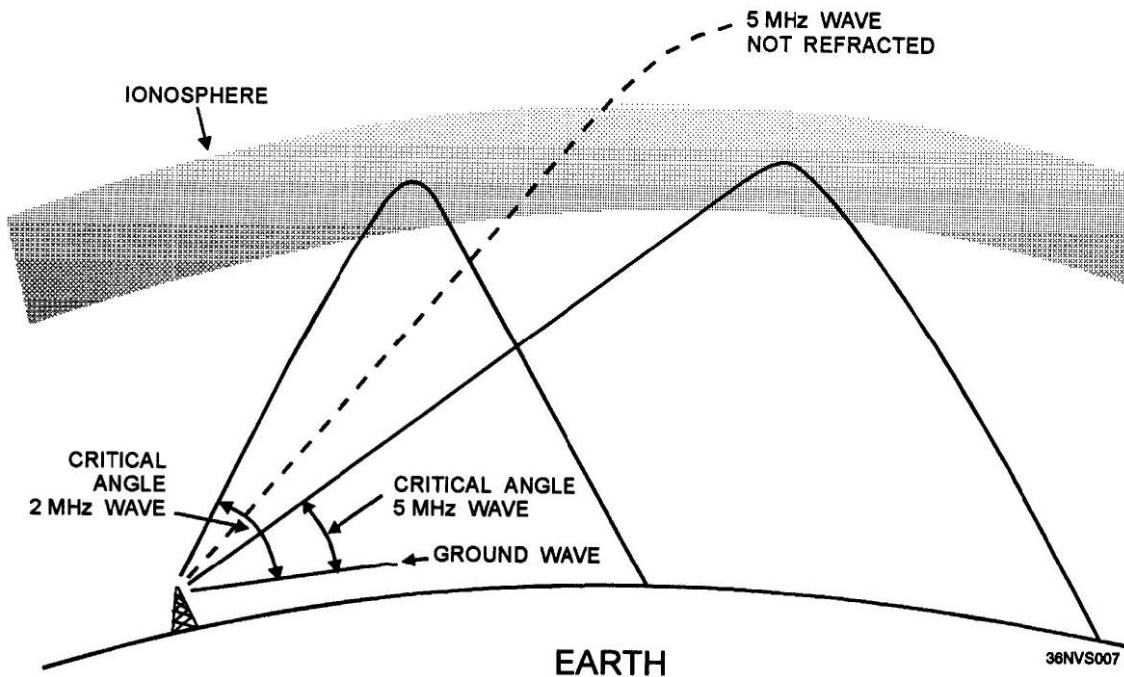

Figure 1-7.—Effect of frequency on the critical angle.



## SKIP DISTANCE AND ZONE

Recall from your previous study that a transmitted radio wave separates into two parts, the sky wave and the ground wave. With those two components in mind, we will now briefly discuss *skip distance* and *skip zone*.

### Skip Distance

Look at the relationship between the sky wave skip distance, skip zone, and ground wave coverage shown in figure 1-8. The *skip distance* is the distance from the transmitter to the point where the sky wave first returns to the earth. The skip distance depends on the wave's frequency and angle of incidence, and the degree of ionization.

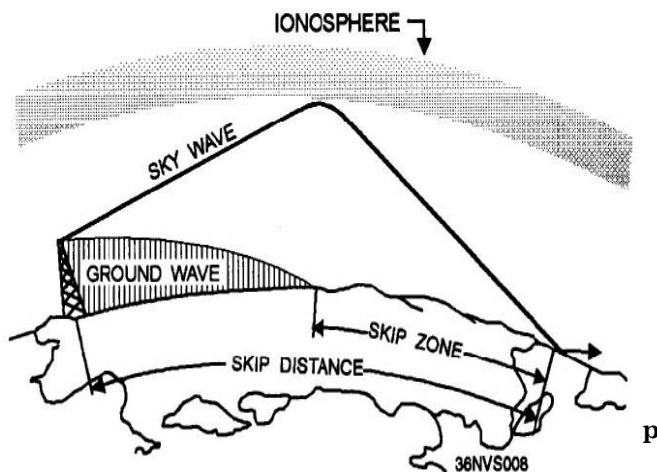

### Skip Zone

The *skip zone* is a zone of silence between the point where the ground wave is too weak for reception and the point where the sky wave is first returned to earth. The outer limit of the skip zone varies considerably, depending on the operating frequency, the time of day, the season of the year, sunspot activity, and the direction of transmission.

At very-low, low, and medium frequencies, a skip zone is never present. However, in the high-frequency spectrum, a skip zone is often present. As the operating frequency is increased, the skip zone widens to a point where the outer limit of the skip zone might be several thousand miles away. At frequencies above a certain maximum, the outer limit of the skip zone disappears completely, and no F-layer propagation is possible.

Occasionally, the first sky wave will return to earth within the range of the ground wave. In this case, severe fading can result from the phase difference between the two waves (the sky wave has a longer path to follow).

### REFLECTION

Reflection occurs when radio waves are "bounced" from a flat surface. There are basically two types of reflection that occur in the atmosphere: earth reflection and ionospheric reflection. Figure 1-9 shows two

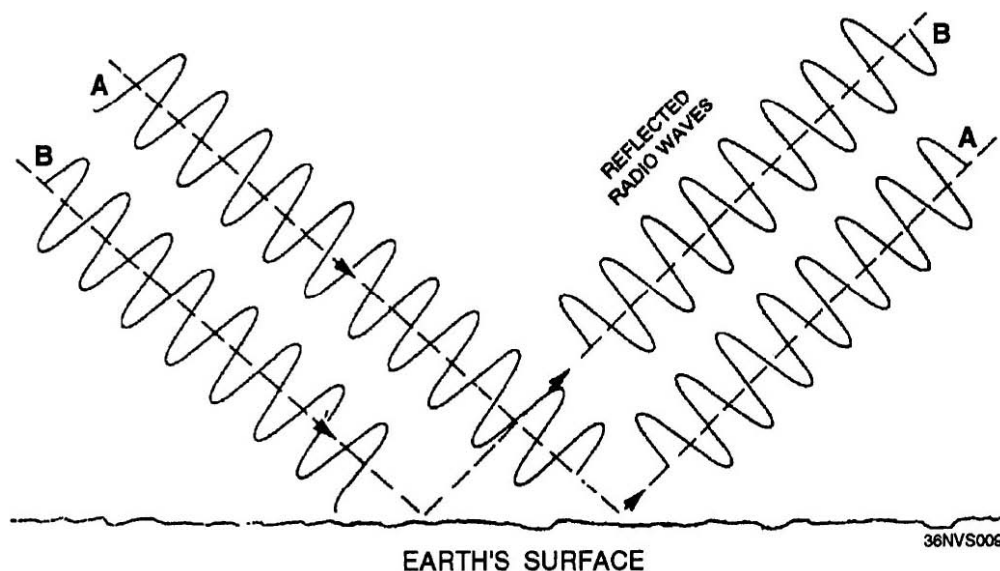

Figure 1-9.—Phase shift of reflected radio waves.

waves reflected from the earth's surface. Waves A and B bounce off the earth's surface like light off of a mirror. Notice that the positive and negative alternations of radio waves A and B are in phase before they strike the earth's surface. However, after reflection the radio waves are approximately 180 degrees out of phase. A phase shift has occurred.

The amount of phase shift that occurs is not constant. It varies, depending on the wave polarization and the angle at which the wave strikes the surface. Because reflection is not constant, fading occurs. Normally, radio waves reflected in phase produce stronger signals, while those reflected out of phase produce a weak or fading signal.

Ionospheric reflection occurs when certain radio waves strike a thin, highly ionized layer in the ionosphere. Although the radio waves are actually refracted, some may be bent back so rapidly that they appear to be reflected. For ionospheric reflection to occur, the highly ionized layer can be approximately no thicker than one wavelength of the wave. Since the ionized layers are often several miles thick, ionospheric reflection mostly occurs at long wavelengths (low frequencies).

## DIFFRACTION

Diffraction is the ability of radio waves to turn sharp corners and bend around obstacles. Shown in figure 1-10, diffraction results in a change of direction of part of the radio-wave energy around the edges of an obstacle. Radio waves with long wavelengths compared to the diameter of an obstruction are easily propagated around the obstruction. However, as the wavelength decreases, the obstruction causes more and more attenuation, until at very-high frequencies a definite *shadow zone* develops. The shadow zone is basically a blank area on the opposite side of an obstruction in line-of-sight from the transmitter to the receiver.

Diffraction can extend the radio range beyond the horizon. By using high power and low-frequencies, radio waves can be made to encircle the earth by diffraction.

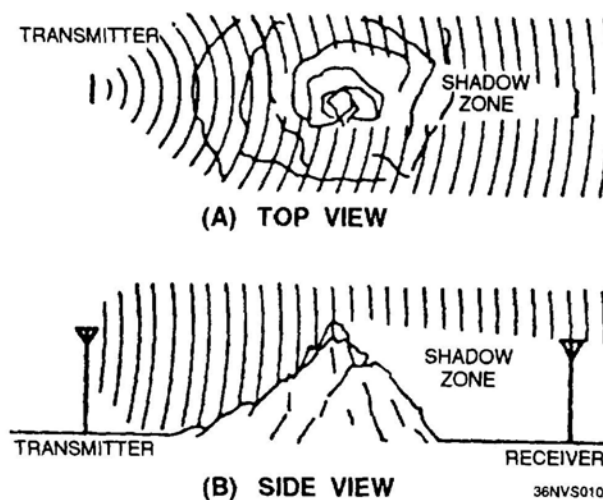

Figure 1-10.—Diffraction around an object.

## ATMOSPHERIC EFFECTS ON PROPAGATION

As we stated earlier, changes in the ionosphere can produce dramatic changes in the ability to communicate. In some cases, communications distances are greatly extended. In other cases, communications distances are greatly reduced or eliminated. The paragraphs below explain the major problem of reduced communications because of the phenomena of fading and selective fading.

### Fading

The most troublesome and frustrating problem in receiving radio signals is variations in signal strength, most commonly known as **FADING**. Several conditions can produce fading. When a radio wave is refracted by the ionosphere or reflected from the earth's surface, random changes in the polarization of the wave may occur. Vertically and horizontally mounted receiving antennas are designed to receive vertically and horizontally polarized waves, respectively. Therefore, changes in polarization cause changes in the received signal level because of the inability of the antenna to receive polarization changes.

Fading also results from absorption of the rf energy in the ionosphere. Most ionospheric absorption occurs in the lower regions of the ionosphere where ionization

density is the greatest. As a radio wave passes into the ionosphere, it loses some of its energy to the free electrons and ions present there. Since the amount of absorption of the radio-wave energy varies with the density of the ionospheric layers, there is no fixed relationship between distance and signal strength for ionospheric propagation. Absorption fading occurs for a longer period than other types of fading, since absorption takes place slowly. Under certain conditions, the absorption of energy is so great that communication over any distance beyond the line of sight becomes difficult.

Although fading because of absorption is the most serious type of fading, fading on the ionospheric circuits is mainly a result of multipath propagation.

### Multipath Fading

*MULTIPATH* is simply a term used to describe the multiple paths a radio wave may follow between transmitter and receiver. Such propagation paths include the ground wave, ionospheric refraction, reradiation by the ionospheric layers, reflection from the earth's surface or from more than one ionospheric layer, and so on. Figure 1-11 shows a few of the paths that a signal can travel between two sites in a typical circuit. One path, XYZ, is the basic ground wave. Another path, XFZ, refracts the wave at the F layer and passes it on to the receiver at point Z. At point Z, the received signal is a combination of the ground wave and the sky wave. These two signals, having traveled different paths, arrive at point Z at different times. Thus, the arriving waves may or may not be in phase with each other. A similar situation may result at point A. Another path, XFZFA, results from a greater angle of incidence and two refractions from the F layer. A wave traveling that path and one traveling the XEA path may or may not arrive at point A in phase. Radio waves that are received in phase reinforce each other and produce a stronger signal at the receiving site, while those that are received out of phase produce a weak or fading signal. Small alterations in the transmission path may change the phase relationship of the two signals, causing periodic fading.

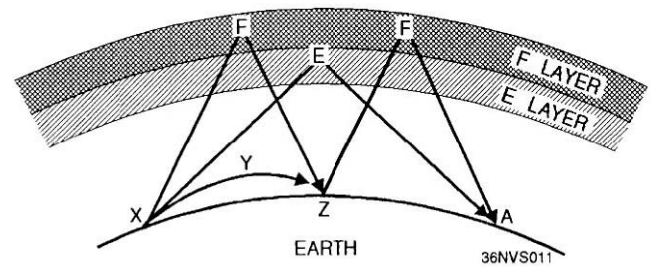

**Figure 1-11.—Multipath transmission.**

Multipath fading may be minimized by practices called **SPACE DIVERSITY** and **FREQUENCY DIVERSITY**. In space diversity, two or more receiving antennas are spaced some distance apart. Fading does not occur simultaneously at both antennas. Therefore, enough output is almost always available from one of the antennas to provide a useful signal.

In frequency diversity, two transmitters and two receivers are used, each pair tuned to a different frequency, with the same information being transmitted simultaneously over both frequencies. One of the two receivers will almost always produce a useful signal.

### Selective Fading

Fading resulting from multipath propagation varies with frequency since each frequency arrives at the receiving point via a different radio path. When a wide band of frequencies is transmitted simultaneously, each frequency will vary in the amount of fading. This variation is called **SELECTIVE FADING**. When selective fading occurs, all frequencies of the transmitted signal do not retain their original phases and relative amplitudes. This fading causes severe distortion of the signal and limits the total signal transmitted.

Frequency shifts and distance changes because of daily variations of the different ionospheric layers are summarized in table 1-1.

Table 1-1.-Daily Ionospheric Communications

<p><b>D LAYER:</b> reflects vlf waves for long-range communications; refracts lf and mf for short-range communications; has little effect on vhf and above; gone at night.</p>	
<p><b>E LAYER:</b> depends on the angle of the sun:refracts hf waves during the day up to 20 MHz to distances of 1200 miles: greatly reduced at night.</p>	
<p><b>F LAYER:</b> structure and density depend on the time of day and the angle of the sun:consists of one layer at night and splits into two layers during daylight hours.</p>	
<p><b>F1 LAYER:</b> density depends on the angle of the sun; its main effect is to absorb hf waves passing through to the F2 layer.</p>	
<p><b>OTHER PHENOMENA THAT AFFECT COMMUNICATIONS</b> F2 layer provides long-range hf communication</p>	

of these layers is greatest during the summer. The F2 layer is just the opposite. Its ionization is greatest during the winter, Therefore, operating frequencies for F2 layer propagation are higher in the winter than in the summer.

Although daily changes in the ionosphere have the greatest effect on communications, other phenomena also affect communications, both positively and negatively. Those phenomena are discussed briefly in the following paragraphs.

**SEASONAL VARIATIONS IN THE IONOSPHERE**

Seasonal variations are the result of the earth's revolving around the sun, because the relative position of the sun moves from one hemisphere to the other with the changes in seasons. Seasonal variations of the D, E, and F1 layers are directly related to the highest angle of the sun, meaning the ionization density

**SUNSPOTS**

One of the most notable occurrences on the surface of the sun is the appearance and disappearance of dark, irregularly shaped areas known as SUNSPOTS. Sunspots are believed to be caused by violent eruptions on the sun and are characterized by strong magnetic fields. These sunspots cause variations in the ionization level of the ionosphere.

Sunspots tend to appear in two cycles, every 27 days and every 11 years.

## **Twenty-Seven Day Cycle**

The number of sunspots present at any one time is constantly changing as some disappear and new ones emerge. As the sun rotates on its own axis, these sunspots are visible at 27-day intervals, which is the approximate period for the sun to make one complete revolution. During this time period, the fluctuations in ionization are greatest in the F2 layer. For this reason, calculating critical frequencies for long-distance communications for the F2 layer is not possible and allowances for fluctuations must be made.

## **Eleven-Year Cycle**

Sunspots can occur unexpectedly, and the life span of individual sunspots is variable. The ELEVEN-YEAR SUN SPOT CYCLE is a regular cycle of sunspot activity that has a minimum and maximum level of activity that occurs every 11 years. During periods of maximum activity, the ionization density of all the layers increases. Because of this, the absorption in the D layer increases and the critical frequencies for the E, F1, and F2 layers are higher. During these times, higher operating frequencies must be used for long-range communications.

## **IRREGULAR VARIATIONS**

Irregular variations are just that, unpredictable changes in the ionosphere that can drastically affect our ability to communicate. The more common variations are sporadic E, ionospheric disturbances, and ionospheric storms.

### **Sporadic E**

Irregular cloud-like patches of unusually high ionization, called the sporadic E, often form at heights near the normal E layer. Their exact cause is not known and their occurrence cannot be predicted. However, sporadic E is known to vary significantly with latitude. In the northern latitudes, it appears to be closely related to the aurora borealis or northern lights.

The sporadic E layer can be so thin that radio waves penetrate it easily and are returned to earth by the upper layers, or it can be heavily ionized and

extend up to several hundred miles into the ionosphere. This condition may be either harmful or helpful to radio-wave propagation.

On the harmful side, sporadic E may blank out the use of higher more favorable layers or cause additional absorption of radio waves at some frequencies. It can also cause additional multipath problems and delay the arrival times of the rays of RF energy.

On the helpful side, the critical frequency of the sporadic E can be greater than double the critical frequency of the normal ionospheric layers. This may permit long-distance communications with unusually high frequencies. It may also permit short-distance communications to locations that would normally be in the skip zone.

Sporadic E can appear and disappear in a short time during the day or night and usually does not occur at same time for all transmitting or receiving stations.

## **Sudden Ionospheric Disturbances**

Commonly known as SID, these disturbances may occur without warning and may last for a few minutes to several hours. When SID occurs, long-range hf communications are almost totally blanked out. The radio operator listening during this time will believe his or her receiver has gone dead.

The occurrence of SID is caused by a bright solar eruption producing an unusually intense burst of ultraviolet light that is not absorbed by the F1, F2, or E layers. Instead, it causes the D-layer ionization density to greatly increase. As a result, frequencies above 1 or 2 megahertz are unable to penetrate the D layer and are completely absorbed.

## **Ionospheric Storms**

Ionospheric storms are caused by disturbances in the earth's magnetic field. They are associated with both solar eruptions and the 27-day cycle, meaning they are related to the rotation of the sun. The effects of ionospheric storms are a turbulent ionosphere and very erratic sky-wave propagation. The storms affect mostly the F2 layer, reducing its ion density and causing the critical frequencies to be lower than

normal. What this means for communication purposes is that the range of frequencies on a given circuit is smaller than normal and that communications are possible only at lower working frequencies.

### Weather

Wind, air temperature, and water content of the atmosphere can combine either to extend radio communications or to greatly attenuate wave propagation, making normal communications extremely difficult. Precipitation in the atmosphere has its greatest effect on the higher frequency ranges. Frequencies in the hf range and below show little effect from this condition.

**RAIN.**— Attenuation because of raindrops is greater than attenuation for any other form of precipitation. Raindrop attenuation may be caused either by absorption, where the raindrop acts as a poor dielectric, absorbs power from the radio wave and dissipates the power by heat loss; or by scattering (fig. 1-13). Raindrops cause greater attenuation by scattering than by absorption at frequencies above 100 megahertz. At frequencies above 6 gigahertz, attenuation by raindrop scatter is even greater.

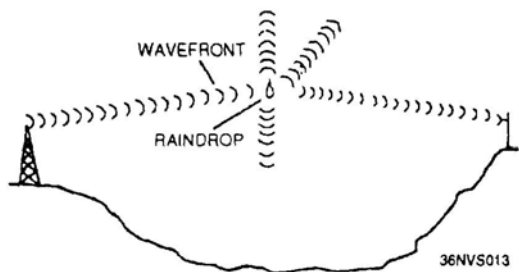

Figure 1-13.—Rf energy losses from scattering.

**FOG.**— Since fog remains suspended in the atmosphere, the attenuation is determined by the quantity of water per unit volume (density of the fog) and by the size of the droplets. Attenuation because of fog has little effect on frequencies lower than 2 gigahertz, but can cause serious attenuation by absorption at frequencies above 2 gigahertz.

**SNOW.**— Since snow has about 1/8 the density of rain, and because of the irregular shape of the

snowflake, the scattering and absorption losses are difficult to compute, but will be less than those caused by raindrops.

**HAIL.**— Attenuation by hail is determined by the size of the stones and their density. Attenuation of radio waves by scattering because of hailstones is considerably less than by rain.

### TEMPERATURE INVERSION

When layers of warm air form above layers of cold air, the condition known as temperature inversion develops. This phenomenon causes ducts or channels to be formed, by sandwiching cool air either between the surface of the earth and a layer of warm air, or between two layers of warm air. If a transmitting antenna extends into such a duct, or if the radio wave enters the duct at a very low angle of incidence, vhf and uhf transmissions may be propagated far beyond normal line-of-sight distances. These long distances are possible because of the different densities and refractive qualities of warm and cool air. The sudden change in densities when a radio wave enters the warm air above the duct causes the wave to be refracted back toward earth. When the wave strikes the earth or a warm layer below the duct, it is again reflected or refracted upward and proceeds on through the duct with a multiple-hop type of action. An example of radio-wave propagation by ducting is shown in figure 1-14.

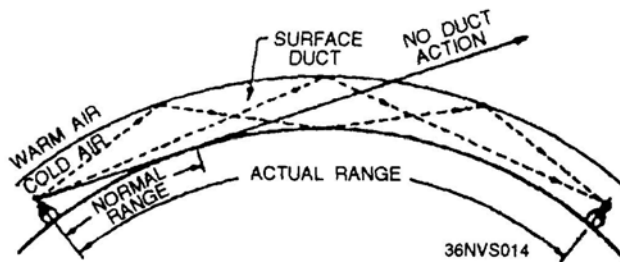

Figure 1-14.—Duct effect caused by temperature inversion.

### TRANSMISSION LOSSES

All radio waves propagated over the ionosphere undergo energy losses before arriving at the receiving site. As we discussed earlier, absorption and lower

atmospheric levels in the ionosphere account for a large part of these energy losses. There are two other types of losses that also significantly affect propagation. These losses are known as *ground reflection losses* and *freespace loss*. The combined effect of absorption ground reflection loss, and freespace loss account for most of the losses of radio transmissions propagated in the ionosphere.

### GROUND REFLECTION LOSS

When propagation is accomplished via multihop refraction, rf energy is lost each time the radio wave is reflected from the earth's surface. The amount of energy lost depends on the frequency of the wave, the angle of incidence, ground irregularities, and the electrical conductivity of the point of reflection.

### FREESPACE LOSS

Normally, the major loss of energy is because of the spreading out of the wavefront as it travels from the transmitter. As distance increases, the area of the wavefront spreads out, much like the beam of a flashlight. This means the amount of energy contained within any unit of area on the wavefront decreases as distance increases. By the time the energy arrives at the receiving antenna, the wavefront is so spread out that the receiving antenna extends into only a small portion of the wavefront. This is illustrated in figure 1-15.

### FREQUENCY SELECTION

You must have a thorough knowledge of radio-wave propagation to exercise good judgment when selecting transmitting and receiving antennas and operating frequencies. Selecting a usable operating frequency within your given allocations and availability is of prime importance to maintaining reliable communications.

For successful communication between any two specified locations at any given time of the day, there is a maximum frequency, a lowest frequency and an optimum frequency that can be used.

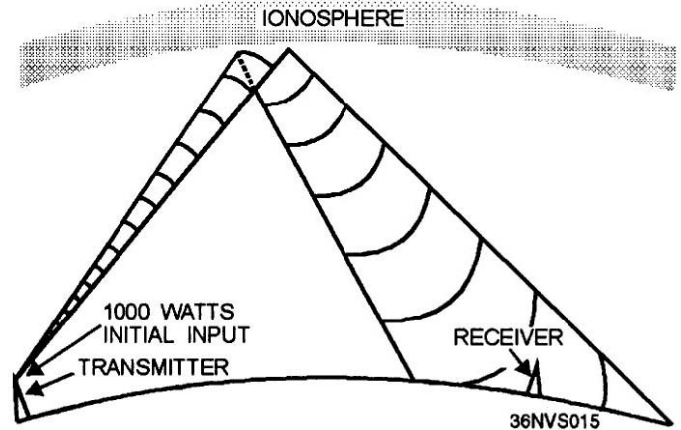

Figure 1-15.—Freespace loss principle.

### MAXIMUM USABLE FREQUENCY

The higher the frequency of a radio wave, the lower the rate of refraction by the ionosphere. Therefore, for a given angle of incidence and time of day, there is a maximum frequency that can be used for communications between two given locations. This frequency is known as the **MAXIMUM USABLE FREQUENCY** (muf).

Waves at frequencies above the muf are normally refracted so slowly that they return to earth beyond the desired location or pass on through the ionosphere and are lost. Variations in the ionosphere that can raise or lower a predetermined muf may occur at anytime. This is especially true for the highly variable F2 layer.

### LOWEST USABLE FREQUENCY

Just as there is a muf that can be used for communications between two points, there is also a minimum operating frequency that can be used known as the **LOWEST USABLE FREQUENCY** (luf). As the frequency of a radio wave is lowered, the rate of refraction increases. So a wave whose frequency is below the established luf is refracted back to earth at a shorter distance than desired, as shown in figure 1 16.

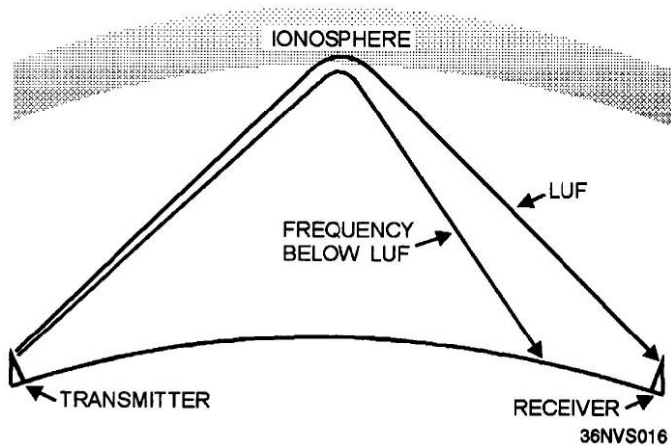

**Figure 1-16.—Refraction of frequencies below the lowest usable frequency (luf).**

As a frequency is lowered, absorption of the radio wave increases. A wave whose frequency is too low is absorbed to such an extent that it is too weak for reception. Atmospheric noise is also greater at lower frequencies. A combination of higher absorption and atmospheric noise could result in an unacceptable signal-to-noise ratio.

For a given angle ionospheric conditions, of incidence and set of the luf depends on the refraction

properties of the ionosphere, absorption considerations, and the amount of noise present.

### OPTIMUM WORKING FREQUENCY

The most practical operating frequency is one that you can rely onto have the least number of problems. It should be high enough to avoid the problems of multipath fading, absorption, and noise encountered at the lower frequencies; but not so high as to be affected by the adverse effects of rapid changes in the ionosphere.

A frequency that meets the above criteria is known as the **OPTIMUM WORKING FREQUENCY**. It is abbreviated “**fot**” from the initial letters of the French words for optimum working frequency, “*frequence optimum de travail*.” The fot is roughly about 85% of the muf, but the actual percentage varies and may be considerably more or less than 85 percent.

In this chapter, we discussed the basics of radio-wave propagation and how atmospheric conditions determine the operating parameters needed to ensure successful communications. In chapter 2, we will discuss basic antenna operation and design to complete your understanding of radio-wave propagation.



## CHAPTER 2

# ANTENNA

As an Electronics Technician, you are responsible for maintaining systems that both radiate and receive electromagnetic energy. Each of these systems requires some type of antenna to make use of this electromagnetic energy. In this chapter we will discuss antenna characteristics, different antenna types, antenna tuning, and antenna safety.

### ANTENNA CHARACTERISTICS

An antenna may be defined as a conductor or group of conductors used either for radiating electromagnetic energy into space or for collecting it from space. Electrical energy from the transmitter is converted into electromagnetic energy by the antenna and radiated into space. On the receiving end, electromagnetic energy is converted into electrical energy by the antenna and fed into the receiver.

The electromagnetic radiation from an antenna is made up of two components, the E field and the H field. The total energy in the radiated wave remains constant in space except for some absorption of energy by the earth. However, as the wave advances, the energy spreads out over a greater area. This causes the amount of energy in a given area to decrease as distance from the source increases.

The design of the antenna system is very important in a transmitting station. The antenna must be able to radiate efficiently so the power supplied by the transmitter is not wasted. An efficient transmitting antenna must have exact dimensions, determined by the frequency being transmitted. The dimensions of the receiving antenna are not critical for relatively low frequencies, but their importance increases drastically as the transmitted frequency increases.

Most practical transmitting antennas are divided into two basic classifications, HERTZ ANTENNAS (half-wave) and MARCONI (quarter-wave) ANTENNAS. Hertz antennas are generally installed some distance above the ground and are positioned to radiate

either vertically or horizontally. Marconi antennas operate with one end grounded and are mounted perpendicular to the earth or a surface acting as a ground. The Hertz antenna, also referred to as a dipole, is the basis for some of the more complex antenna systems used today. Hertz antennas are generally used for operating frequencies of 2 MHz and above, while Marconi antennas are used for operating frequencies below 2 MHz.

All antennas, regardless of their shape or size, have four basic characteristics: reciprocity, directivity, gain, and polarization.

### RECIPROCITY

RECIPROCITY is the ability to use the same antenna for both transmitting and receiving. The electrical characteristics of an antenna apply equally, regardless of whether you use the antenna for transmitting or receiving. The more efficient an antenna is for transmitting a certain frequency, the more efficient it will be as a receiving antenna for the same frequency. This is illustrated by figure 2-1, view A. When the antenna is used for transmitting, maximum radiation occurs at right angles to its axis. When the same antenna is used for receiving (view B), its best reception is along the same path; that is, at right angles to the axis of the antenna.

### DIRECTIVITY

The DIRECTIVITY of an antenna or array is a measure of the antenna's ability to focus the energy in one or more specific directions. You can determine an antenna's directivity by looking at its radiation pattern. In an array propagating a given amount of energy, more radiation takes place in certain directions than in others. The elements in the array can be arranged so they change the pattern and distribute the energy more evenly in all directions. The opposite is also possible. The elements can be arranged so the radiated energy is *focused* in one direction. The

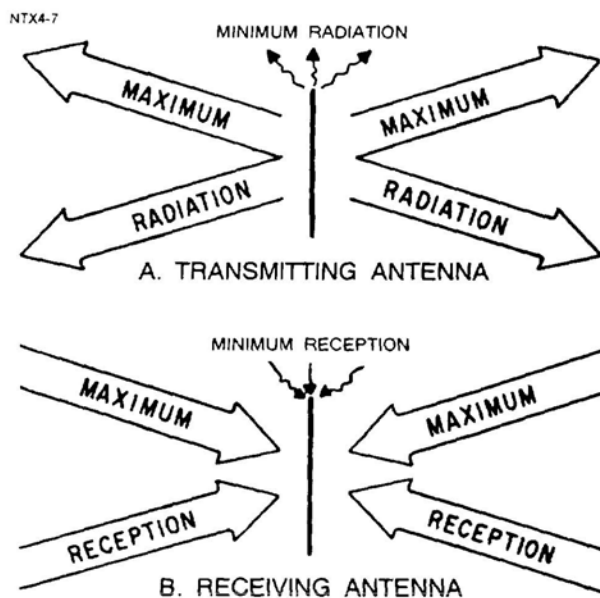

Figure 2-1.—Reciprocity of antennas.

elements can be considered as a group of antennas fed from a common source.

## GAIN

As we mentioned earlier, some antennas are highly directional. That is, they propagate more energy in certain directions than in others. The ratio between the amount of energy propagated in these directions and the energy that would be propagated if the antenna were not directional is known as antenna GAIN. The gain of an antenna is constant, whether the antenna is used for transmitting or receiving.

## POLARIZATION

Energy from an antenna is radiated in the form of an expanding sphere. A small section of this sphere is called a wavefront, positioned perpendicular to the direction of the radiation field (fig. 2-2). Within this wavefront, all energy is in phase. Usually, all points on the wavefront are an equal distance from the antenna. The farther from the antenna the wave is, the less curved it appears. At a considerable distance, the wavefront can be considered as a plane surface at right angles to the direction of propagation.

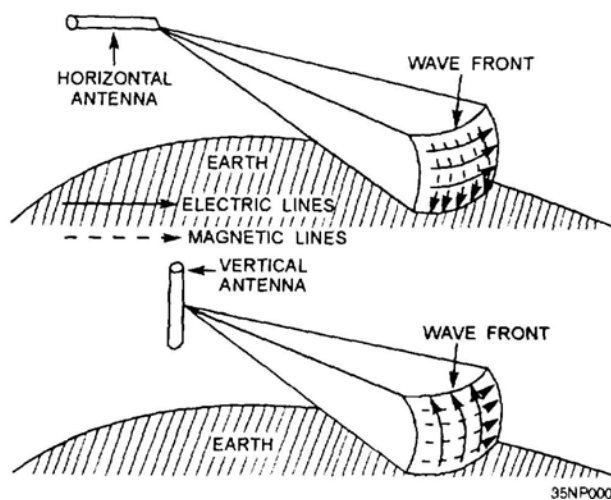

Figure 2-2.—Horizontal and vertical polarization.

The radiation field is made up of magnetic and electric lines of force that are always at right angles to each other. Most electromagnetic fields in space are said to be linearly polarized. The direction of polarization is the direction of the electric vector. That is, if the electric lines of force (E lines) are horizontal, the wave is said to be horizontally polarized (fig. 2-2), and if the E lines are vertical, the wave is said to be vertically polarized. Since the electric field is parallel to the axis of the dipole, the antenna is in the plane of polarization.

A horizontally placed antenna produces a horizontally polarized wave, and a vertically placed antenna produces a vertically polarized wave.

In general, the polarization of a wave does not change over short distances. Therefore, transmitting and receiving antennas are oriented alike, especially if they are separated by short distances.

Over long distances, polarization changes. The change is usually small at low frequencies, but quite drastic at high frequencies. (For radar transmissions, a received signal is actually a wave reflected from an object. Since signal polarization varies with the type of object, no set position of the receiving antenna is correct for all returning signals). Where separate antennas are used for transmitting and receiving, the receiving antenna is generally polarized in the same direction as the transmitting antenna.

When the transmitting antenna is close to the ground, it should be polarized vertically, because vertically polarized waves produce a greater signal strength along the earth's surface. On the other hand, when the transmitting antenna is high above the ground, it should be horizontally polarized to get the greatest signal strength possible to the earth's surface.

### RADIATION OF ELECTROMAGNETIC ENERGY

Various factors in the antenna circuit affect the radiation of electromagnetic energy. In figure 2-3, for example, if an alternating current is applied to the A end of wire antenna AB, the wave will travel along the wire until it reaches the B end. Since the B end is free, an open circuit exists and the wave cannot travel further. This is a point of high impedance. The wave bounces back (reflects) from this point of high impedance and travels toward the starting point, where it is again reflected. Theoretically, the energy of the wave should be gradually dissipated by the resistance of the wire during this back-and-forth motion (oscillation). However, each time the wave reaches the starting point, it is reinforced by an impulse of energy sufficient to replace the energy lost during its travel along the wire. This results in continuous oscillations of energy along the wire and a high voltage at the A end of the wire. These oscillations move along the antenna at a rate equal to the frequency of the rf voltage and are sustained by properly timed impulses at point A.

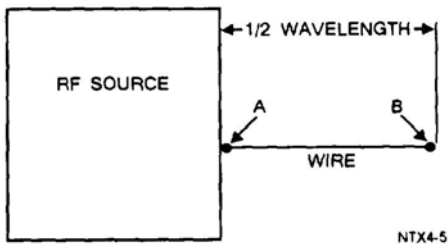

Figure 2-3.—Antenna and rf source.

The rate at which the wave travels along the wire is constant at approximately 300,000,000 meters per second. The length of the antenna must be such that a wave will travel from one end to the other and back again during the period of 1 cycle of the rf voltage.

The distance the wave travels during the period of 1 cycle is known as the wavelength. It is found by dividing the rate of travel by the frequency.

Look at the current and voltage distribution on the antenna in figure 2-4. A maximum movement of electrons is in the center of the antenna at all times; therefore, the center of the antenna is at a low impedance.

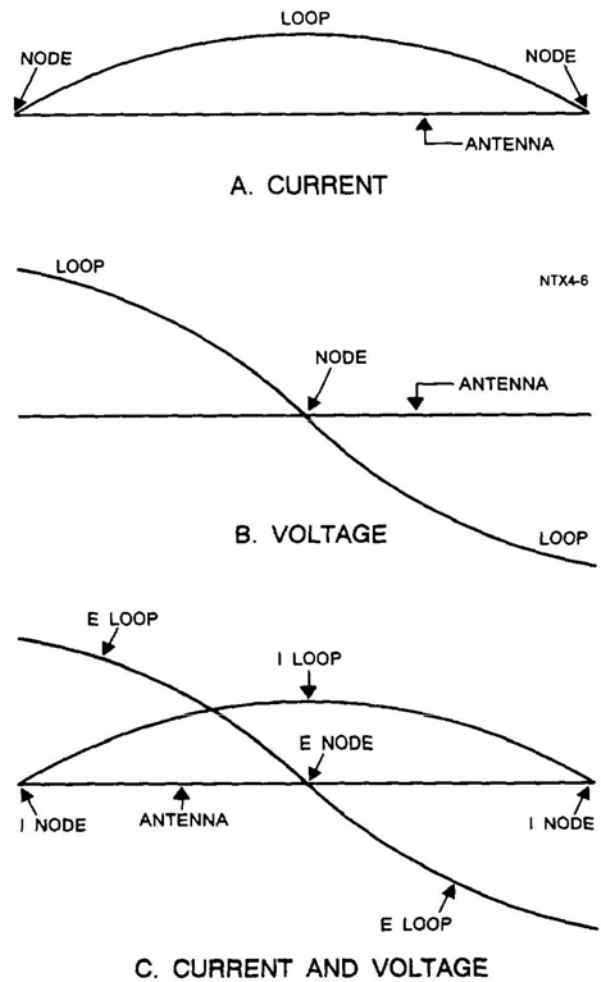

Figure 2-4.—Standing waves of current and voltage on an antenna.

This condition is called a STANDING WAVE of current. The points of high current and high voltage are known as current and voltage LOOPS. The points of minimum current and minimum voltage are known as current and voltage NODES. View A shows a current loop and two current nodes. View B shows two voltage loops and a voltage node. View C shows

the resultant voltage and current loops and nodes. The presence of standing waves describes the condition of resonance in an antenna. At resonance, the waves travel back and forth in the antenna, reinforcing each other, and are transmitted into space at maximum radiation. When the antenna is not at resonance, the waves tend to cancel each other and energy is lost in the form of heat.

### RADIATION TYPES AND PATTERNS

A logical assumption is that energy leaving an antenna radiates equally over 360 degrees. This is not the case for every antenna.

The energy radiated from an antenna forms a field having a definite RADIATION PATTERN. The radiation pattern for any given antenna is determined by measuring the radiated energy at various angles at constant distances from the antenna and then plotting the energy values on a graph. The shape of this pattern depends on the type of antenna being used.

Some antennas radiate energy equally in all directions. Radiation of this type is known as ISOTROPIC RADIATION. The sun is a good example of an isotropic radiator. If you were to measure the amount of radiated energy around the sun's circumference, the readings would all be fairly equal (fig. 2-5).

Most radiators emit (radiate) energy more strongly in one direction than in another. These radiators are referred to as ANISOTROPIC radiators. A flashlight is a good example of an anisotropic radiator (fig. 2-6). The beam of the flashlight lights only a portion of the space surrounding it. The area behind the flashlight remains unlit, while the area in front and to either side is illuminated.

### MAJOR AND MINOR LOBES

The pattern shown in figure 2-7, view B, has radiation concentrated in two lobes. The radiation intensity in one lobe is considerably stronger than in the other. The lobe toward point X is called a MAJOR LOBE; the other is a MINOR LOBE. Since the complex radiation patterns associated with antennas frequently contain several lobes of varying intensity,

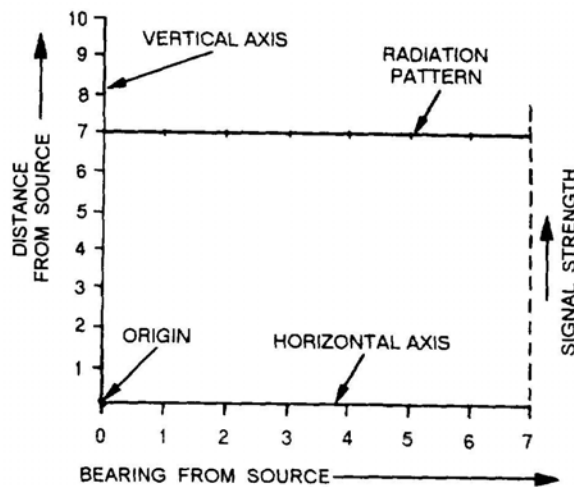

A. RECTANGULAR-COORDINATE GRAPH

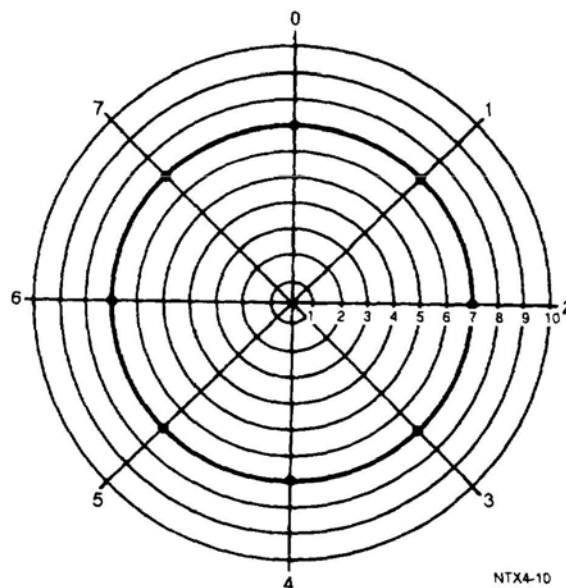

B. POLAR-COORDINATE GRAPH

Figure 2-5.—Isotropic radiation graphs.

you should learn to use the appropriate terminology, In general, major lobes are those in which the greatest amount of radiation occurs. Minor lobes are those in which the least amount of radiation occurs.

### ANTENNA LOADING

There will be times when you may want to use one antenna system to transmit on several different frequencies. Since the antenna must always be in resonance with the applied frequency, you must either lengthen it or shorten it to produce the required

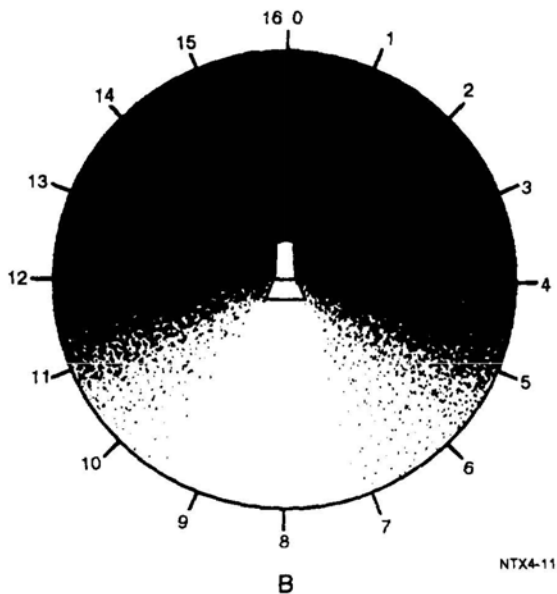
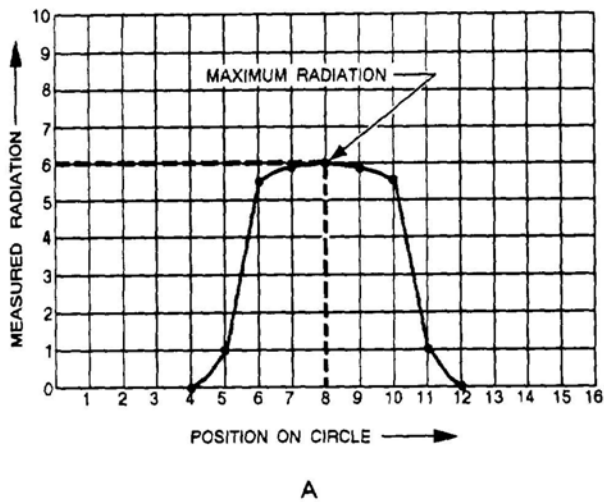

Figure 2-6.—Anisotropic radiator.

resonance. Changing the antenna dimensions physically is impractical, but changing them electrically is relatively simple. To change the electrical length of an antenna, you can insert either an inductor or a capacitor in series with the antenna. This is shown in figure 2-8, views A and B. Changing the electrical length by this method is known as LUMPED-IMPEDANCE TUNING or LOADING. If the antenna is too short for the wavelength being used, it will be resonant at a higher frequency. Therefore, it offers a capacitive reactance at the excitation frequency. This capacitive reactance can be compensated for by introducing a lumped inductive reactance, as shown in view A. Similarly, if the

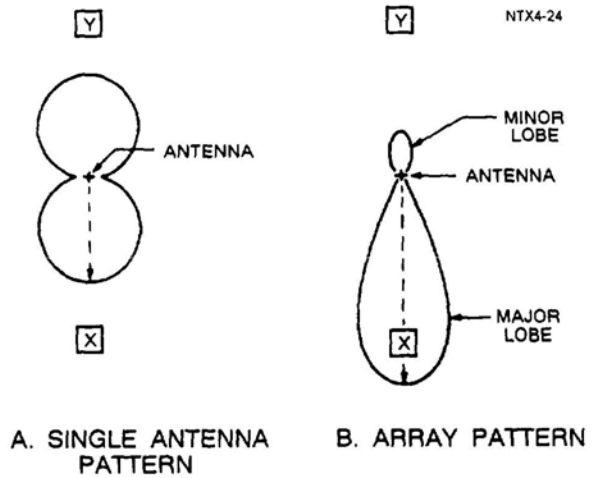

Figure 2-7.—Major and minor lobes.

antenna is too long for the transmitting frequency, it will be resonant at a lower frequency and offers an inductive reactance. Inductive reactance can be compensated for by introducing a lumped capacitive reactance, as shown in view B. An antenna with normal loading is represented in view C.

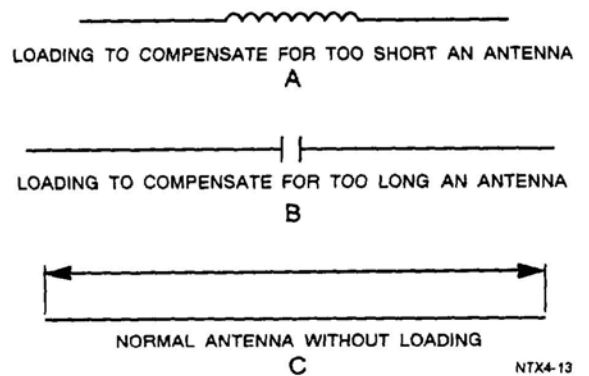
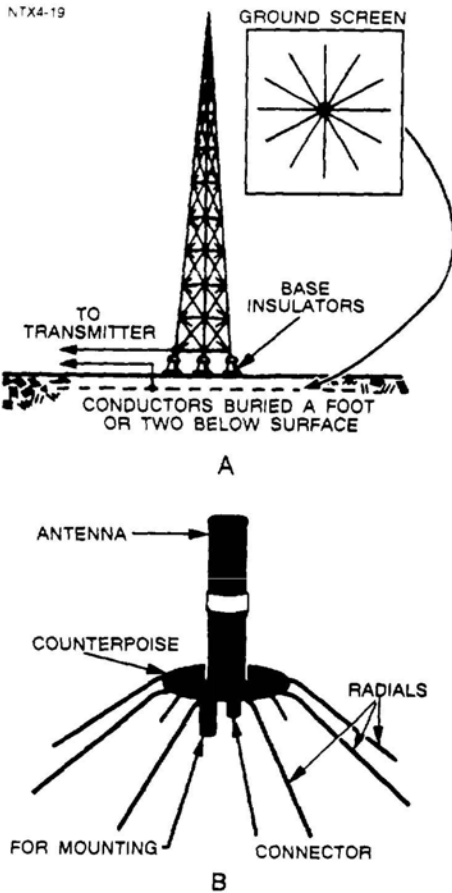

Figure 2-8.—Electrical antenna loading.

### GROUND EFFECTS

As we discussed earlier, ground losses affect radiation patterns and cause high signal losses for some frequencies. Such losses can be greatly reduced if a good conducting ground is provided in the vicinity of the antenna. This is the purpose of the GROUND SCREEN (fig. 2-9, view A) and COUNTERPOISE (fig. 2-9, view B).



**Figure 2-9.—Ground screen and counterpoise.**

Some antennas can be used in both shore-based and ship-based applications. Others, however, are designed to be used primarily in one application or the other. The following paragraphs discuss, by frequency range, antennas used for shore-based communications.

**VERY LOW FREQUENCY (VLF)**

The main difficulty in vlf and lf antenna design is the physical disparity between the maximum practical size of the antenna and the wavelength of the frequency it must propagate. These antennas must be large to compensate for wavelength and power handling requirements (0.25 to 2 MW). Transmitting antennas for vlf have multiple towers 600 to 1500 feet high, an extensive flat top for capacitive loading, and a copper ground system for reducing ground losses. Capacitive top-loading increases the bandwidth characteristics, while the ground plane improves radiation efficiency.

Representative antenna configurations are shown in figures 2-10 through 2-12. Variations of these basic antennas are used at the majority of the Navy vlf sites.

The ground screen in view A is composed of a series of conductors arranged in a radial pattern and buried 1 or 2 feet below the surface of the earth. These conductors, each usually 1/2 wavelength long, reduce ground absorption losses in the vicinity of the antenna.

A counterpoise (view B) is used when easy access to the base of the antenna is necessary. It is also used when the area below the antenna is not a good conducting surface, such as solid rock or ground that is sandy. The counterpoise serves the same purpose as the ground screen but is usually elevated above the earth. No specific dimensions are necessary for a counterpoise, nor is the number of wires particularly critical. The primary requirement is that the counterpoise be insulated from ground and form a grid of reflector elements for the antenna system.

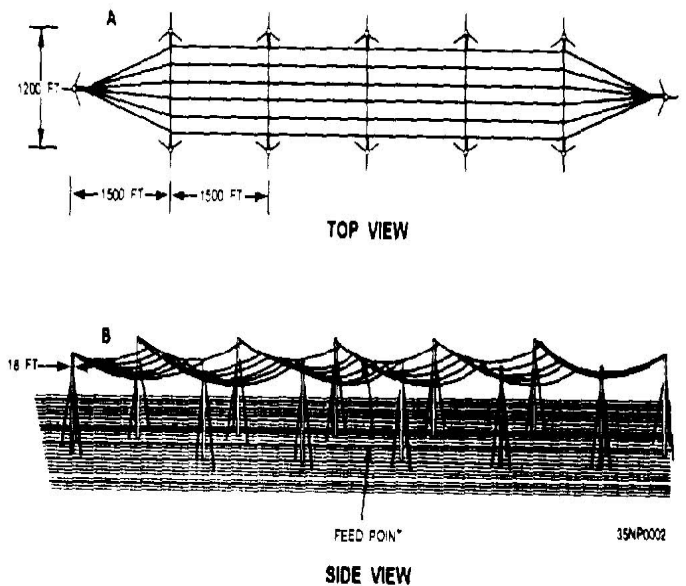

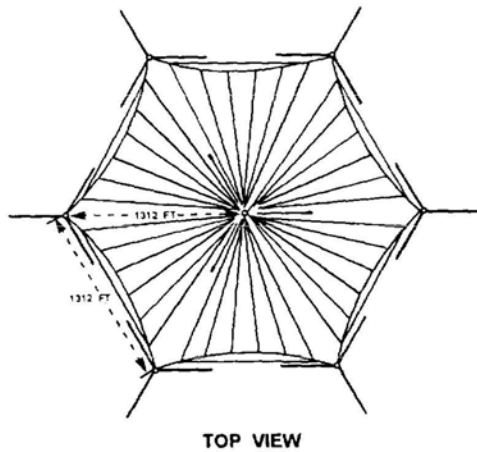

TOP VIEW

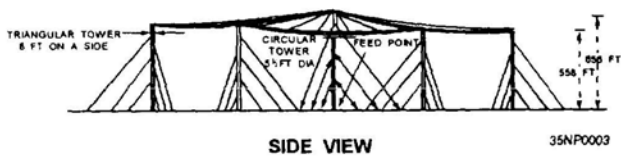

SIDE VIEW

35NP0003

Figure 2-11.—Goliath-type antenna.

### LOW FREQUENCY (LF)

Antennas for lf are not quite as large as antennas for vlf, but they still occupy a large surface area. Two examples of lf antenna design are shown in figures 2-13 and 2-14. The Pan polar antenna (fig. 2-13) is an umbrella top-loaded monopole. It has three loading loops spaced 120 degrees apart, interconnected between the tower guy cables. Two of the loops terminate at ground, while the other is used as a feed. The NORD antenna (fig. 2-14), based on the the folded-unipole principle, is a vertical tower radiator grounded at the base and fed by one or more wires connected to the top of the tower. The three top loading wires extend from the top of the antenna at 120-degree intervals to three terminating towers. Each loading wire has a length approximately equal to the height of the main tower plus 100 feet. The top loading wires are insulated from ground and their tower supports are one-third the height of the transmitting antenna.

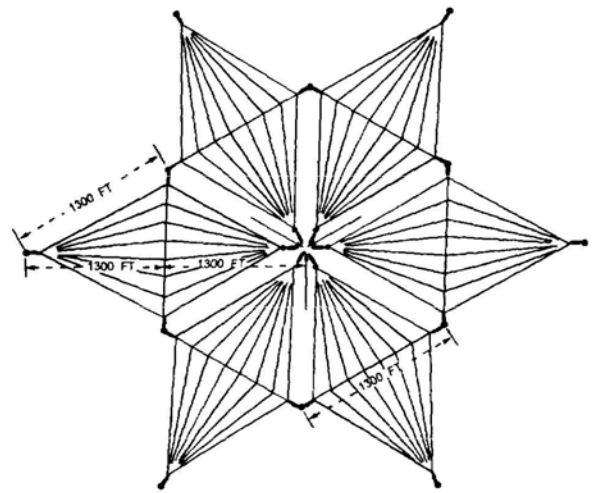

TOP VIEW

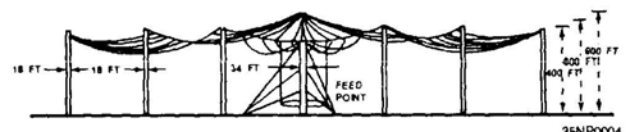

SIDE VIEW

35NP0004

Figure 2-12.—Trideco-type antenna.

### HIGH FREQUENCY (HF)

High-frequency (hf) radio antenna systems are used to support many different types of circuits, including ship-to-shore, point-to-point, and ground-to-air broadcast. These diverse applications require the use of various numbers and types of antennas that we will review on the following pages.

#### Yagi

The Yagi antenna is an end-fired parasitic array. It is constructed of parallel and coplaner dipole elements arranged along a line perpendicular to the axis of the dipoles, as illustrated in figure 2-15. The most limiting characteristic of the Yagi antenna is its extremely narrow bandwidth. Three percent of the center frequency is considered to be an acceptable bandwidth ratio for a Yagi antenna. The width of the array is determined by the lengths of the elements. The length of each element is approximately one-half

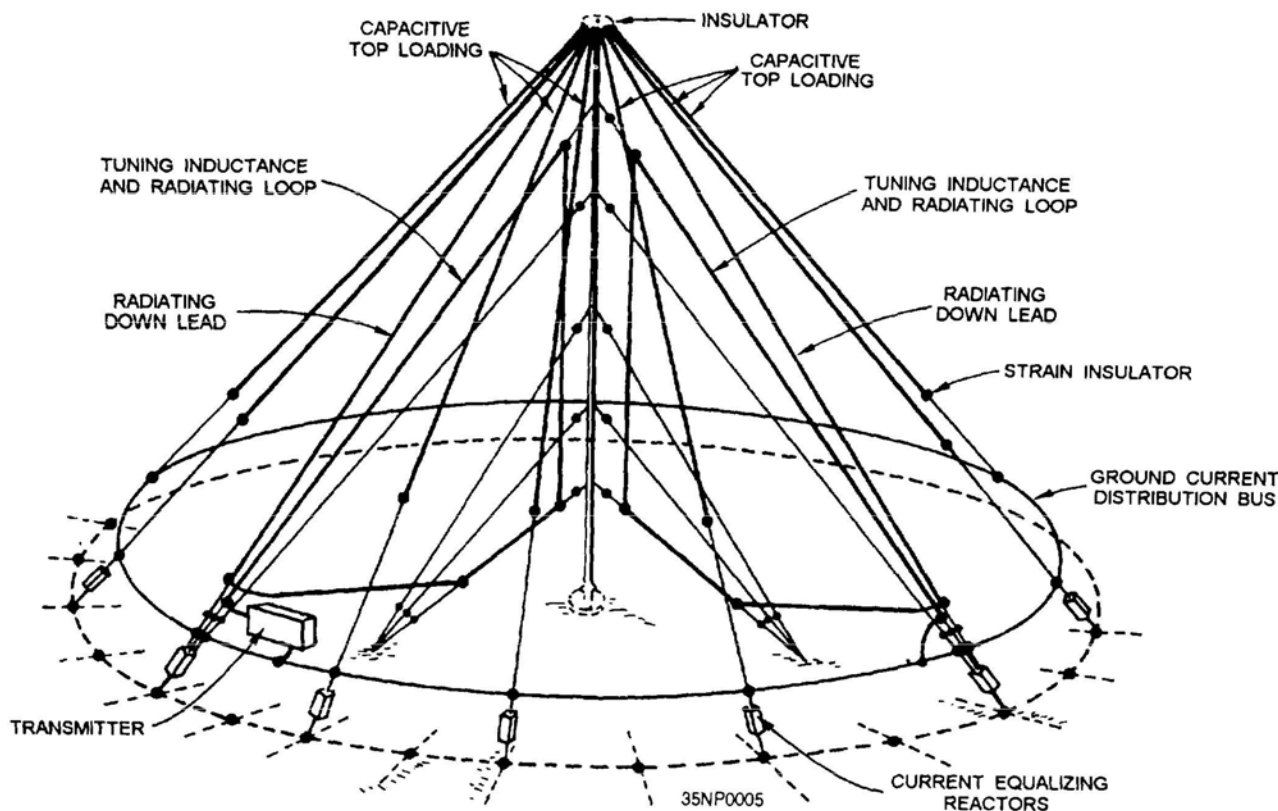

Figure 2-13.—Pan polar antenna.

wavelength, depending on its intended use (driver, reflector, or director). The required length of the array depends on the desired gain and directivity. Typically, the length will vary from 0.3 wavelength for three-element arrays, to 3 wavelengths for arrays with numerous elements. For hf applications, the maximum practical array length is 2 wavelengths. The array's height above ground will determine its vertical radiation angle. Normally, array heights vary from 0.25 to 2.5 wavelengths. The dipole elements are usually constructed from tubing, which provides for better gain and bandwidth characteristics and provides sufficient mechanical rigidity for self-support. Yagi arrays of four elements or less are not structurally complicated. Longer arrays and arrays for lower frequencies, where the width of the array exceeds 40 feet, require elaborate booms and supporting structures. Yagi arrays may be either fixed-position or rotatable.

#### LOG-PERIODIC ANTENNAS (LPAs)

An antenna arranged so the electrical length and spacing between successive elements causes the input

impedance and pattern characteristics to be repeated periodically with the logarithm of the driving frequency is called a LOG-PERIODIC ANTENNA (LPA). The LPA, in general, is a medium-power, high-gain, moderately-directive antenna of extremely broad bandwidth. Bandwidths of up to 15:1 are possible, with up to 15 dB power gain. LPAs are rather complex antenna systems and are relatively expensive. The installation of LPAs is normally more difficult than for other hf antennas because of the tower heights involved and the complexity of suspending the radiating elements and feedlines from the towers.

#### Vertical Monopole LPA

The log-periodic vertical monopole antenna (fig. 2-16) has the plane containing the radiating elements in a vertical field. The longest element is approximately one-quarter wavelength at the lower cutoff frequency. The ground system for the monopole arrangement provides the image equivalent of the other quarter wavelength for the half-dipole radiating elements. A typical vertical monopole designed to



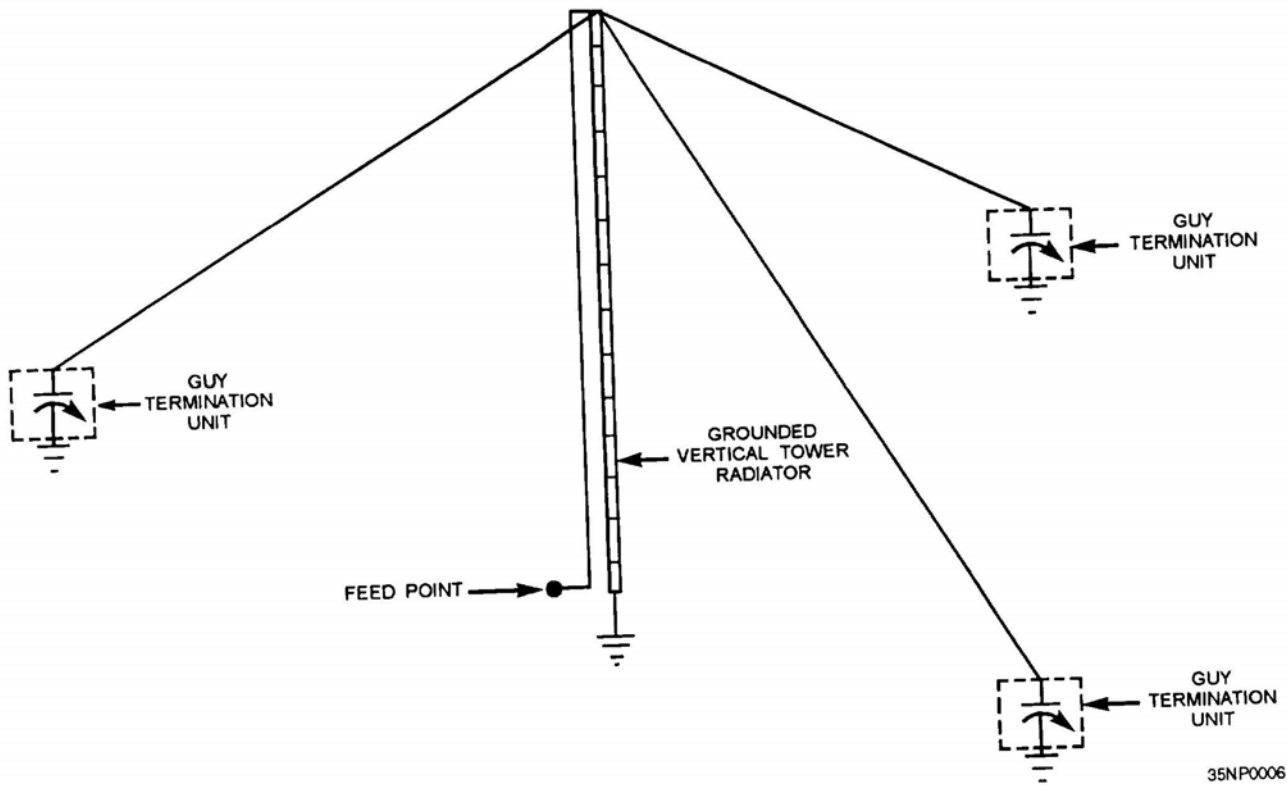

Figure 2-14.—NORD antenna.

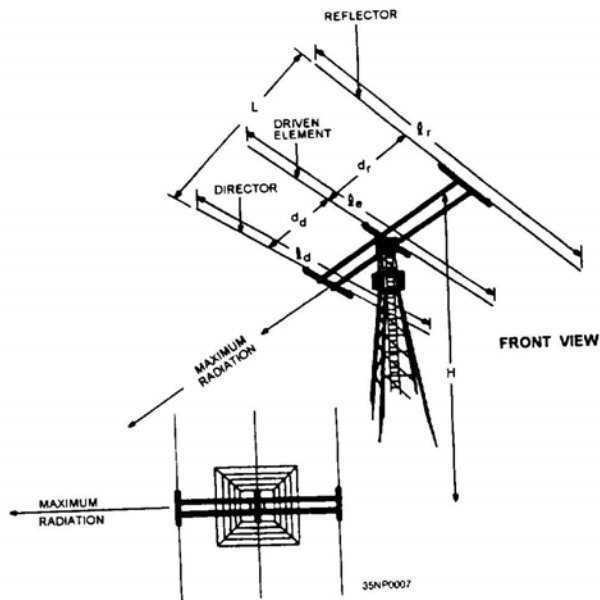

Figure 2-15.—Yagi antenna.

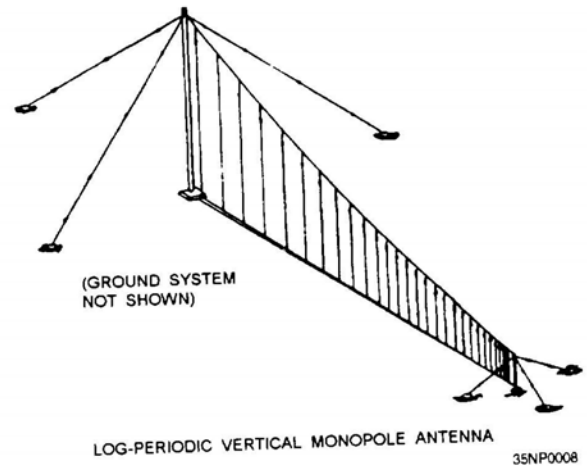

Figure 2-16.—Log-periodic vertical monopole antenna.

cover a frequency range of 2 to 30 MHz requires one tower approximately 140 feet high and an antenna length of around 500 feet, with a ground system that covers approximately 3 acres of land in the immediate vicinity of the antenna.

### Sector Log-Periodic Array

This version of a vertically polarized fixed-azimuth LPA consists of four separate curtains supported by a common central tower, as shown in figure 2-17. Each of the four curtains operates independently, providing antennas for a minimum of four transmit or receive systems, and a choice of sector coverage. The four curtains are also capable of radiating a rosette pattern of overlapping sectors for full coverage, as shown by the radiation pattern in figure 2-17. The central supporting tower is constructed of steel and may range to approximately 250 feet in height, with the length of each curtain reaching 250 feet, depending on its designed operating frequencies. A sector antenna that uses a ground plane designed to cover the entire hf spectrum takes up 4 to 6 acres of land area.

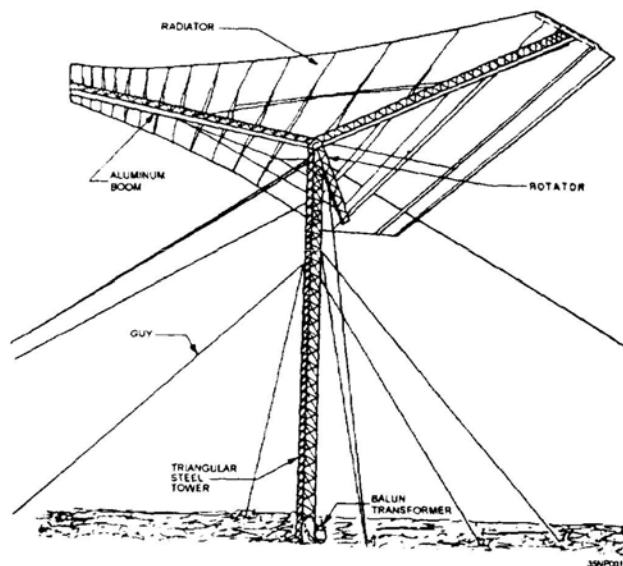
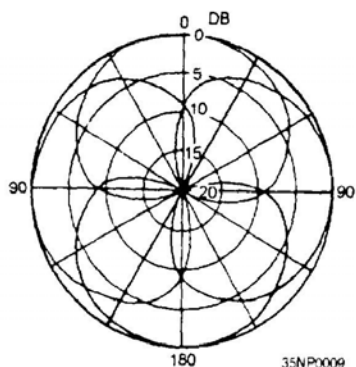
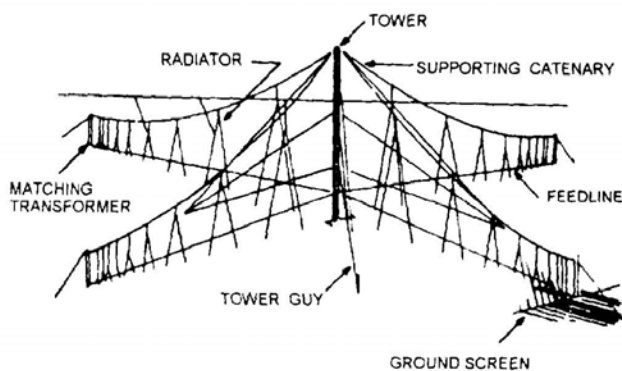

Figure 2-18.—Rotatable log-periodic antenna.

### Rotatable LPA (RLPA)

RLPAs (fig. 2-18) are commonly used in ship-to-shore-to-ship and in point-to-point ecm-u-nunications. Their distinct advantage is their ability to rotate 360 degrees. RLPAs are usually constructed with either tubular or wire antenna elements. The RLPA in figure 2-18 has wire elements strung on three aluminum booms of equal length, spaced equally and arranged radially about a central rotator on top of a steel tower approximately 100 feet high. The frequency range of this antenna is 6 to 32 MHz. The gain is 12 dB with respect to isotropic antennas. Power handling capability is 20 kw average, and vswr is 2:1 over the frequency range.

### INVERTED CONE ANTENNA

Inverted cone antennas are vertically polarized, omnidirectional, and have an extremely broad bandwidth. They are widely used for ship-to-shore and ground-to-air communications. Inverted cone antennas are installed over a radial ground plane system and are supported by poles, as shown in figure 2-19. The equally-spaced vertical radiator wires terminate in a feed ring assembly located at the bottom center, where a 50-ohm coaxial transmission line feeds the antenna. Inverted cones usually have gains of 1 to 5 dB above isotropic antennas, with a vswr not

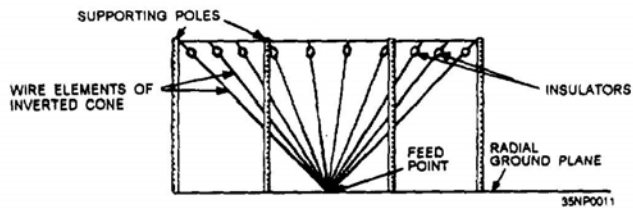

Figure 2-19.—Inverted cone antenna.

greater than 2:1. They are considered medium- to high-power radiators, with power handling capabilities of 40 kW average power.

### CONICAL MONOPOLE ANTENNA

Conical monopoles are used extensively in hf communications. A conical monopole is an efficient broadband, vertically polarized, omnidirectional antenna in a compact size. Conical monopoles are shaped like two truncated cones connected base-to-base. The basic conical monopole configuration, shown in figure 2-20, is composed of equally-spaced wire radiating elements arranged in a circle around an aluminum center tower. Usually, the radiating elements are connected to the top and bottom discs, but on some versions, there is a center waist disc where the top and bottom radiators are connected. The conical monopole can handle up to 40 kW of average power. Typical gain is -2 to +2 dB, with a vswr of up to 2.5:1.

### RHOMBIC ANTENNA

Rhombic antennas can be characterized as high-power, low-angle, high-gain, horizontally-polarized, highly-directive, broadband antennas of simple, inexpensive construction. The rhombic antenna (fig. 2-21) is a system of long-wire radiators that depends on radiated wave interaction for its gain and directivity. A properly designed rhombic antenna presents to the transmission line an input impedance insensitive to frequency variations up to 5:1. It maintains a power gain above 9 dB anywhere within a 2:1 frequency variation. At the design-center frequency, a gain of 17 dB is typical. The radiation pattern produced by the four radiating legs of a rhombic antenna is modified by reflections from the earth under, and immediately in front of, the antenna. Because of the importance of these ground

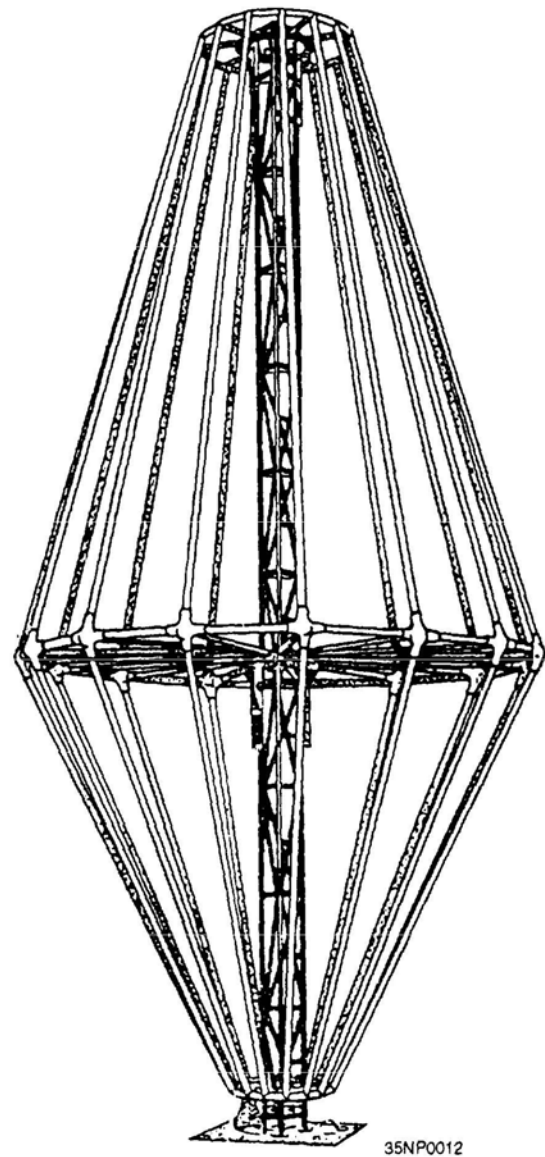
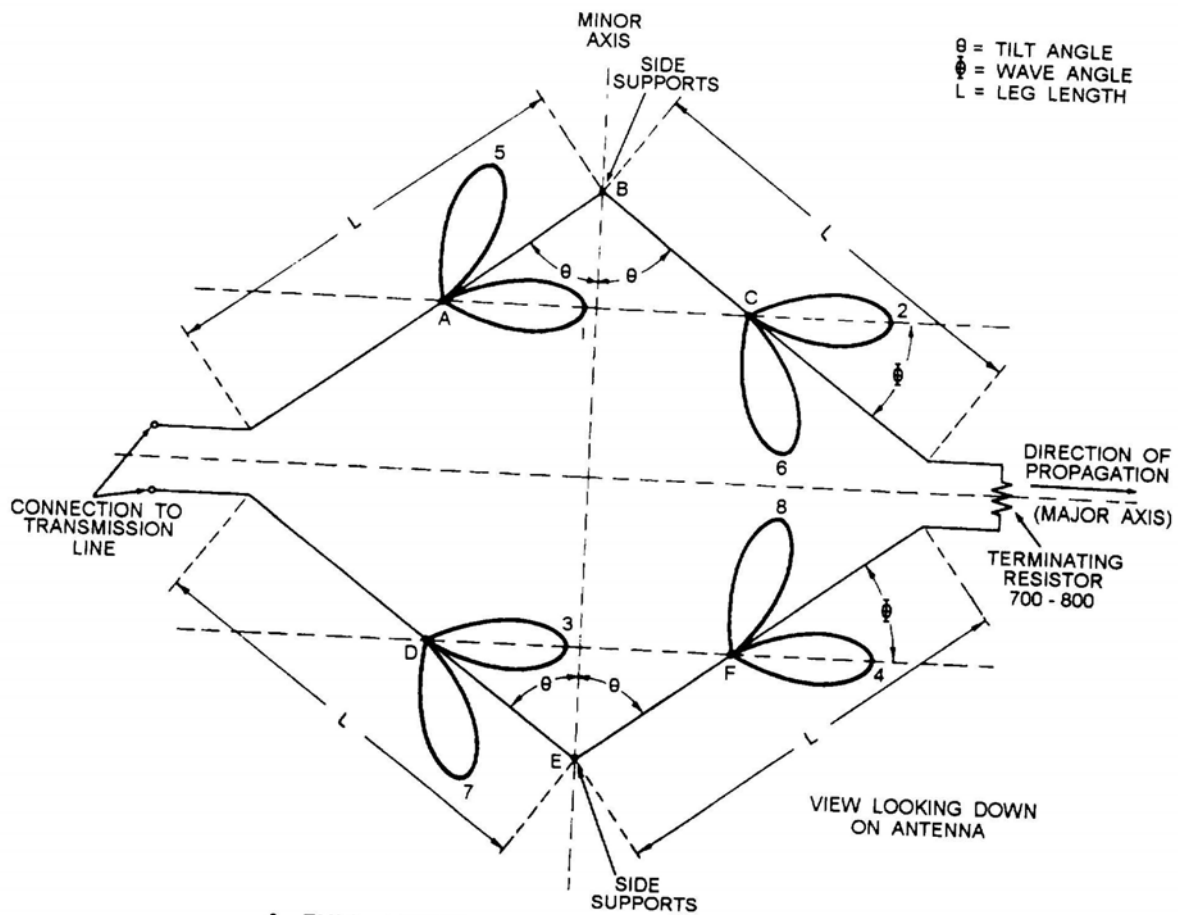

Figure 2-20.—Conical monopole antenna.

reflections in the proper formation of the main lobe, the rhombic should be installed over reasonably smooth and level ground. The main disadvantage of the rhombic antenna is the requirement for a large land area, usually 5 to 15 acres.

### QUADRANT ANTENNA

The hf quadrant antenna (fig. 2-22) is a special-purpose receiving antenna used in ground-to-air-to-ground communications. It is unique among horizontally-polarized antennas because its



**A. FULL - RHOMBIC TRANSMITTING ANTENNA**

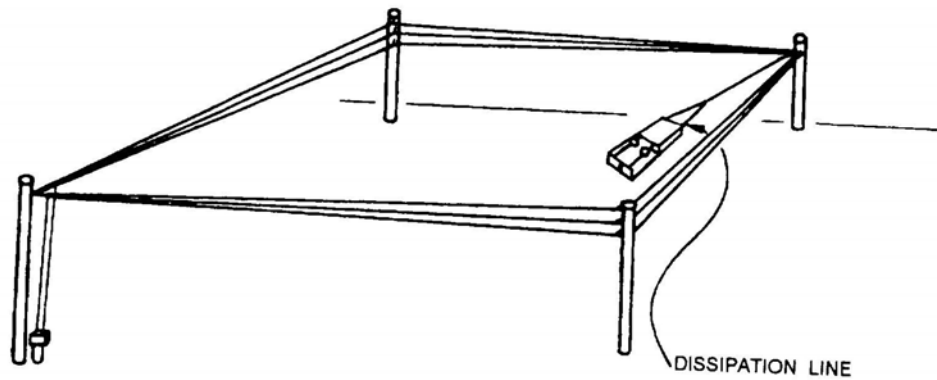

**B. NON - RESONANT HORIZONTAL THREE - WIRE RHOMBIC**

35NP0013

**Figure 2-21.—Three-wire rhombic antenna.**

element arrangement makes possible a radiation pattern resembling that of a vertically-polarized, omnidirectional antenna. Construction and installation of this antenna is complex because of the physical

relationships between the individual elements and the requirement for a separate transmission line for each dipole. Approximately 2.2 acres of land are required to accommodate the quadrant antenna.

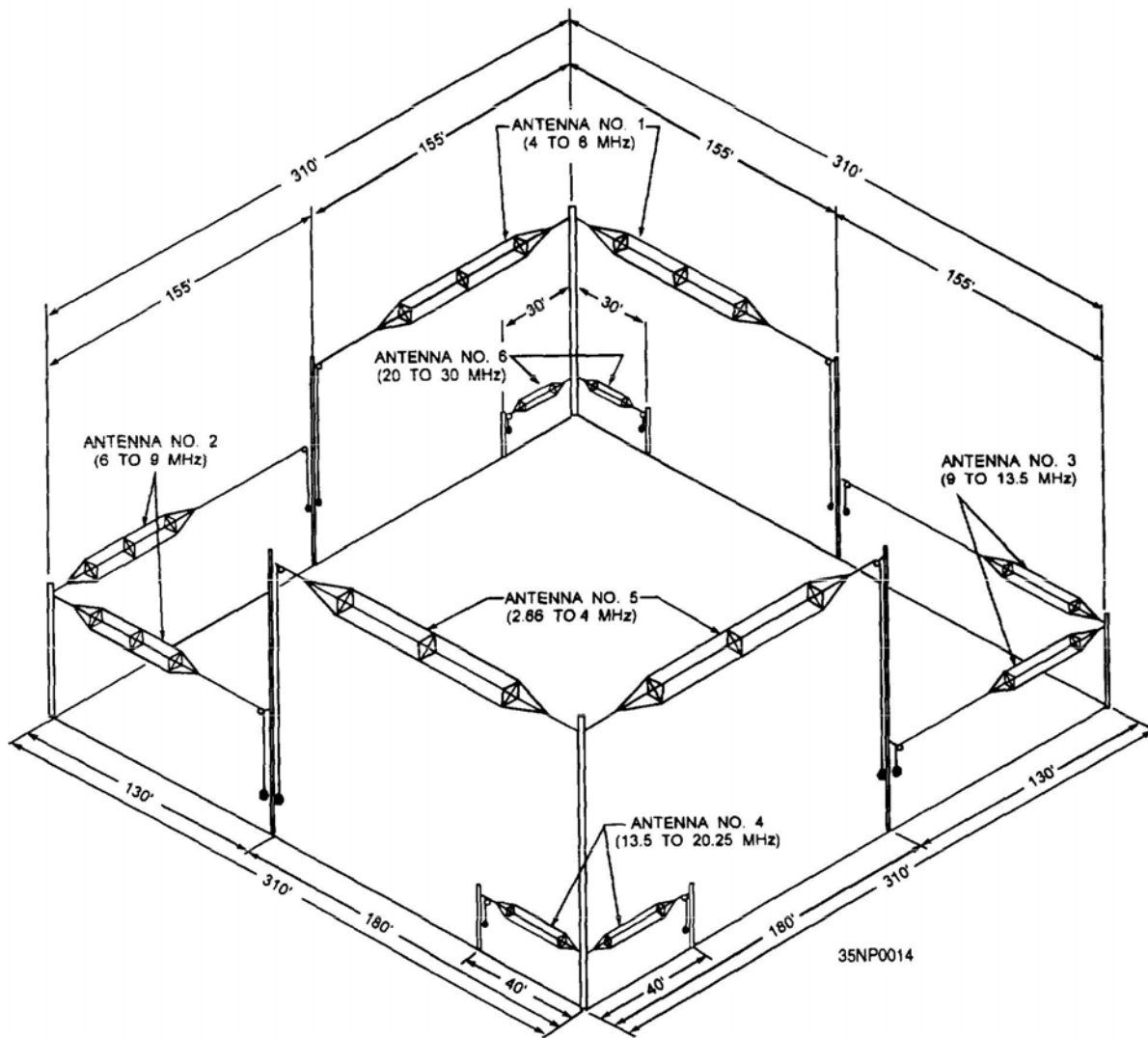

Figure 2-22.—Quadrant antenna.

## WHIP ANTENNAS

Hf whip antennas (fig. 2-23) are vertically-polarized omnidirectional monopoles that are used for short-range, ship-to-shore and transportable communications systems. Whip antennas are made of tubular metal or fiberglass, and vary in length from 12 feet to 35 feet, with the latter being the most prevalent. Although whips are not considered as highly efficient antennas, Figure 2-24 shows installation of a whip antenna. This is a fundamental antenna composed of five wires, power transmitting installations.

The self-supporting feature of the whip makes it particularly useful where space is limited. Whips can be tilted, a design feature that makes them suited for use along the edges of aircraft carrier flight decks. Aboard submarines, they can be retracted into the sail structure.

Most whip antennas require some sort of tuning system and a ground plane to improve their radiation efficiency throughout the hf spectrum. Without an antenna tuning system, whips generally have a narrow bandwidth and are limited in their power handling

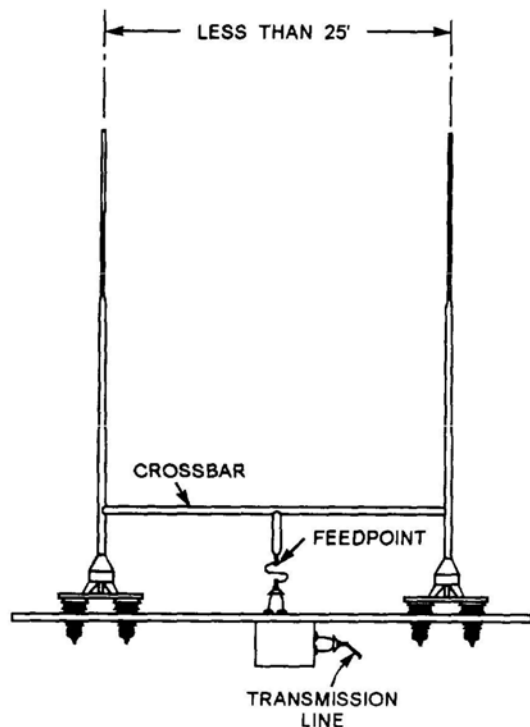

TWIN WHIP ANTENNAS WITH CROSSBAR TERMINATION

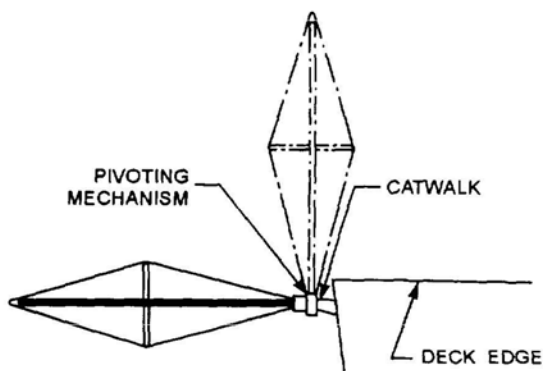

TILTING WHIP ANTENNA

39NP0015

Figure 2-23.—Whip antennas.

capabilities. Power ratings for most whips range from 1 to 5 kW PEP.

### WIRE-ROPE FAN ANTENNAS

Figure 2-24 shows a five-wire vertical fan antenna. This is a broadband antenna composed of five wires, **Figure 2-23.—Whip antennas.** capabilities. Power ratings for most whips range from 1 to 5 kW PEP. **WIRE-ROPE FAN ANTENNAS**

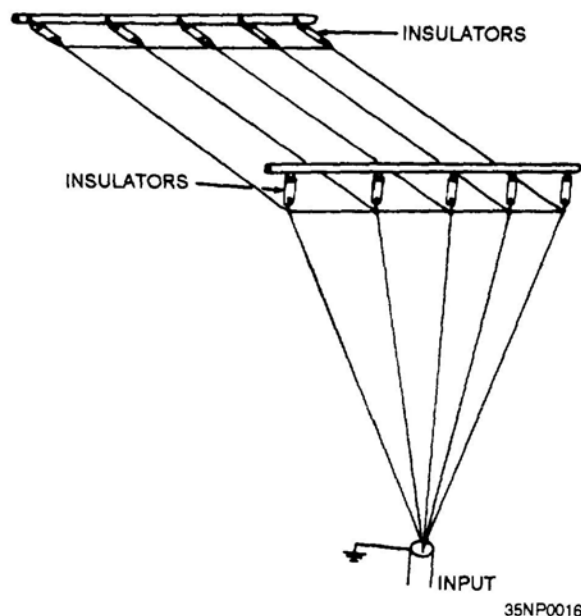

35NP0016

Figure 2-24.—Vertical fan antenna.

each cut for one-quarter wavelength at the lowest frequency to be used. The wires are fanned 30 degrees between adjacent wires. The fan antenna provides satisfactory performance and is designed for use as a random shipboard antenna in the hf range (2-30 MHz).

### DISCAGE ANTENNA

The discage antenna (fig. 2-25) is a broadband omnidirectional antenna. The discage structure consists of two truncated wire rope cones attached base-to-base and supported by a central mast. The lower portion of the structure operates as a cage monopole for the 4- to 12-MHz frequency range. The upper portion operates as a disccone radiator in the 10- to 30-MHz frequency range. Matching networks limit the vswr to not greater than 3:1 at each feed point. Vinyl-covered phosphor bronze wire rope is used for the wire portions. The support mast and other portions are aluminum.

### VHF/UHF

At vhf and uhf frequencies, the shorter wavelength makes the physical size of the antenna relatively small. Aboard ship these antennas are installed as

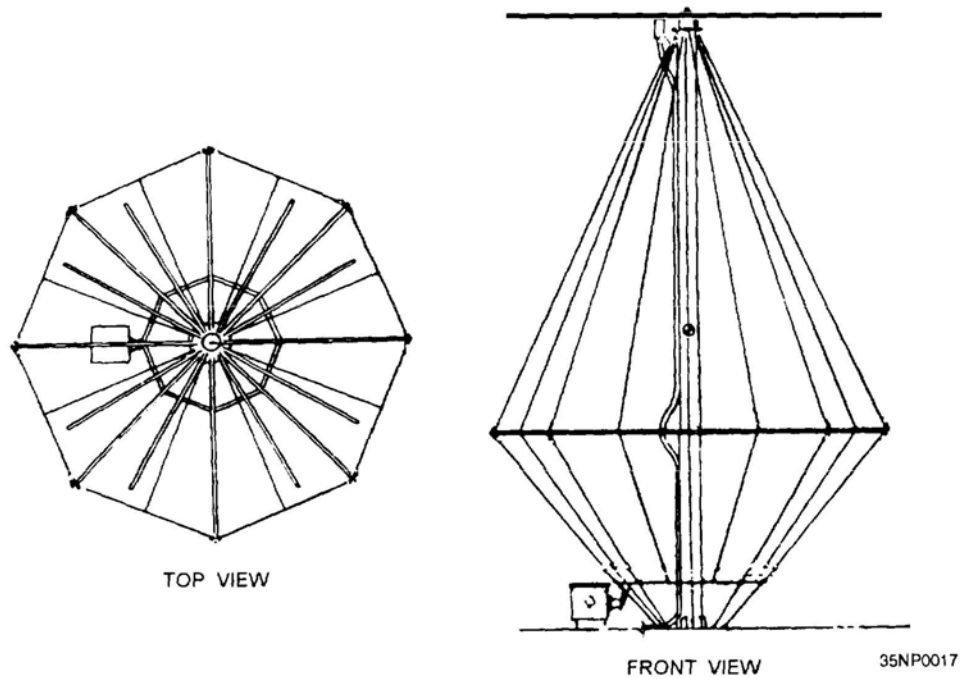

Figure 2-25.—AS-2802/SCR discage antenna.

possible and away from any obstructions. The reason for the high installation is that vertical conductors, such as masts, rigging, and cables in the vicinity, cause unwanted directivity in the radiation pattern.

For best results in the vhf and uhf ranges, both transmitting and receiving antennas must have the same polarization. Vertically polarized antennas (primarily dipoles) are used for all ship-to-ship, ship-to-shore, and air-to-ground vhf and uhf communications.

The following paragraphs describe the most common uhf/vhf dipole antennas. All the examples are vertically-polarized, omnidirectional, broadband antennas.

### Biconical Dipole

The biconical dipole antenna (fig. 2-26) is designed for use at a normal rf power rating of around 250 watts, with a vswr not greater than 2:1. All major components of the radiating and support structures are aluminum. The central feed section is protected and waterproofed by a laminated fiberglass cover.

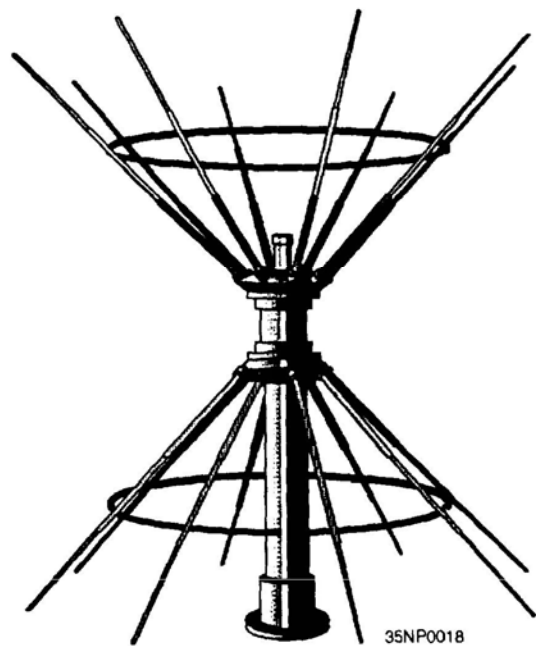

Figure 2-26.—AS-2811/SCR biconical dipole antenna.

## Center-Fed Dipole

The center-fed dipole (fig. 2-27) is designed for use at an average power rating of 100 watts. All major components of the radiating and support structures are aluminum. The central feed section and radiating elements are protected by a laminated fiberglass cover. Center-fed dipole antennas range from 29 to 47 inches in height and have a radiator diameter of up to 3 inches.

## Coaxial Dipole

Figure 2-28 shows two types of coaxial dipoles. The coaxial dipole antenna is designed for use in the uhf range, with an rf power rating of 200 watts. The

Figure 2-28 shows two types of coaxial dipoles. The coaxial dipole antenna is designed for use in the uhf range, with an rf power rating of 200 watts. The

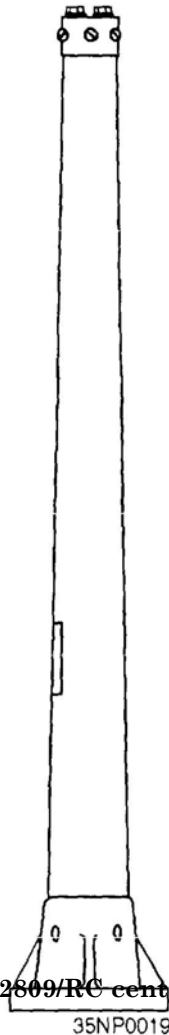

Figure 2-27.—AS-2809/RC center-fed dipole antenna.

35NP0019

AT-150/SRC (fig. 2-28, view A) has vertical radiating elements and a balun arrangement that electrically balances the antenna to ground.

Figure 2-28, view B, shows an AS-390/SRC antenna assembly. This antenna is an unbalanced broadband coaxial stub antenna. It consists of a radiator and a ground plane. The ground plane (or counterpoise) consists of eight elements bent downward 37 degrees from horizontal. The lower ends of the elements form points of a circle 23 inches in diameter. The lower section of the radiator assembly contains a stub for adjusting the input impedance of the antenna. The antenna is vertically polarized, with an rf power rating of 200 watts, and a vswr not greater than 2:1.

## SATELLITE SYSTEMS

The Navy Satellite Communication System (SATCOM) provides communications links, via satellites, between designated mobile units and shore sites. These links supply worldwide communications coverage. The following paragraphs describe some of the more common SATCOM antenna systems to which you will be exposed.

### AS-2815/SRR-1

The AS-2815/SSR-1 fleet broadcast receiving antenna (fig. 2-29) has a fixed 360-degree horizontal pattern with a maximum gain of 4 dB at 90 degrees from the antenna's horizontal plane. The maximum loss in the antenna's vertical pattern sector is 2 dB. The vswr is less than 1.5:1, referenced to 50 ohms. This antenna should be positioned to protect it from interference and possible front end burnout from radar and uhf transmitters.

### ANTENNA GROUPS OE-82B/WSC-1(V) AND OE-82C/WSC-1(V)

Designed primarily for shipboard installations, these antenna groups interface with the AN/WSC-3 transceiver. The complete installation consists of an antenna, bandpass amplifier-filter, switching unit, and antenna control (figs. 2-30 and 2-31). Depending on requirements, one or two antennas may be installed to provide a view of the satellite at all times. The antenna assembly is attached to a pedestal that permits



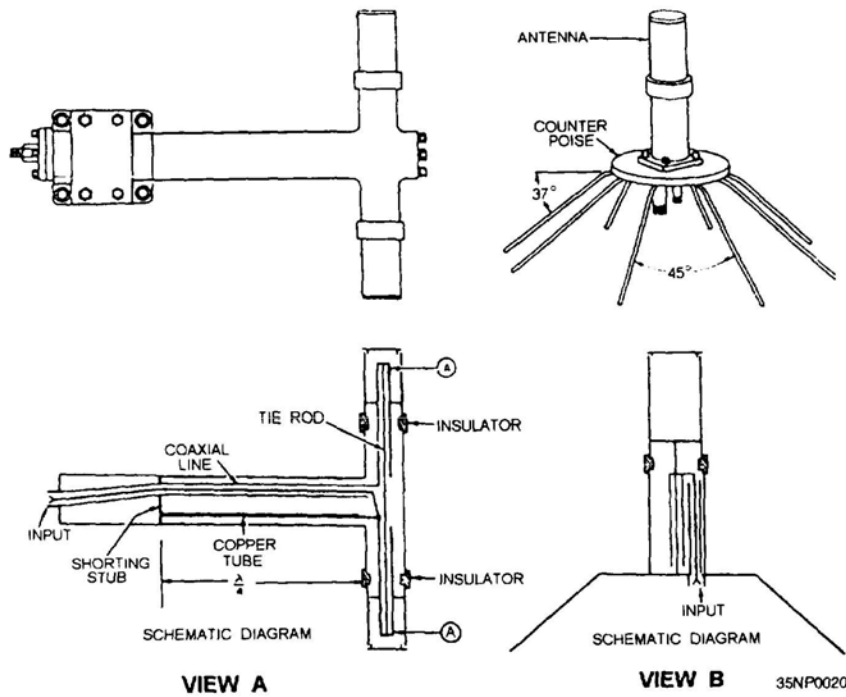

Figure 2-28.—Coaxial dipole.

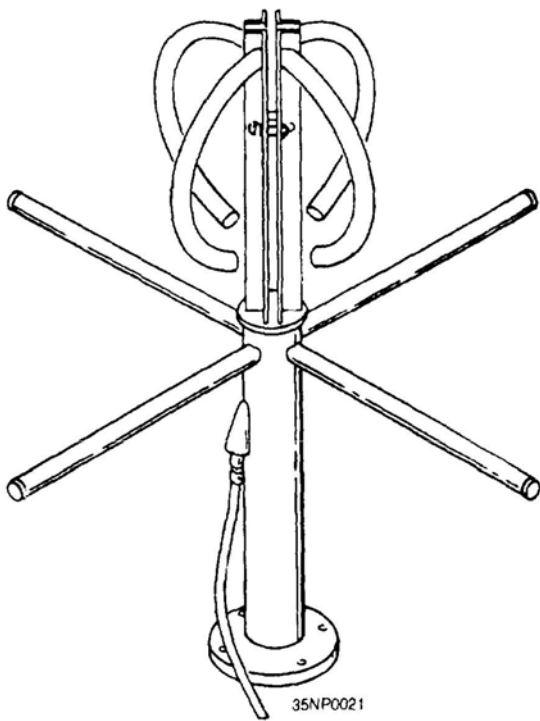

Figure 2-29.—AS-2815/SSR-1 fleet broadcast satellite receiving antenna.

it to rotate 360 degrees and to elevate from near horizontal to approximately 20 degrees beyond zenith (elevation angles from +2 to +110 degrees). The antenna tracks automatically in azimuth and manually in elevation. Frequency bands are 248-272 MHz for receive and 292-312 MHz for transmit. Polarization is right-hand circular for both transmit and receive. Antenna gain characteristics are nominally 12 dB in transmit and 11 dB in receive.

#### AN/WSC-5(V) SHORE STATION ANTENNA

The AN/WSC-5(V) shore station antenna (fig. 2-32) consists of four OE-82A/WSC-1(V) backplane assemblies installed on a pedestal. This antenna is intended for use with the AN/WSC-5(V) transceiver at major shore stations. The antenna is oriented manually and can be locked in position to receive maximum signal strength upon capture of the satellite signal. Hemispherical coverage is 0 to 110 degrees above the horizon. Polarization is right-hand circular in both transmit and receive. The antenna's operating frequency range is 240 to 318 MHz. With its mount,

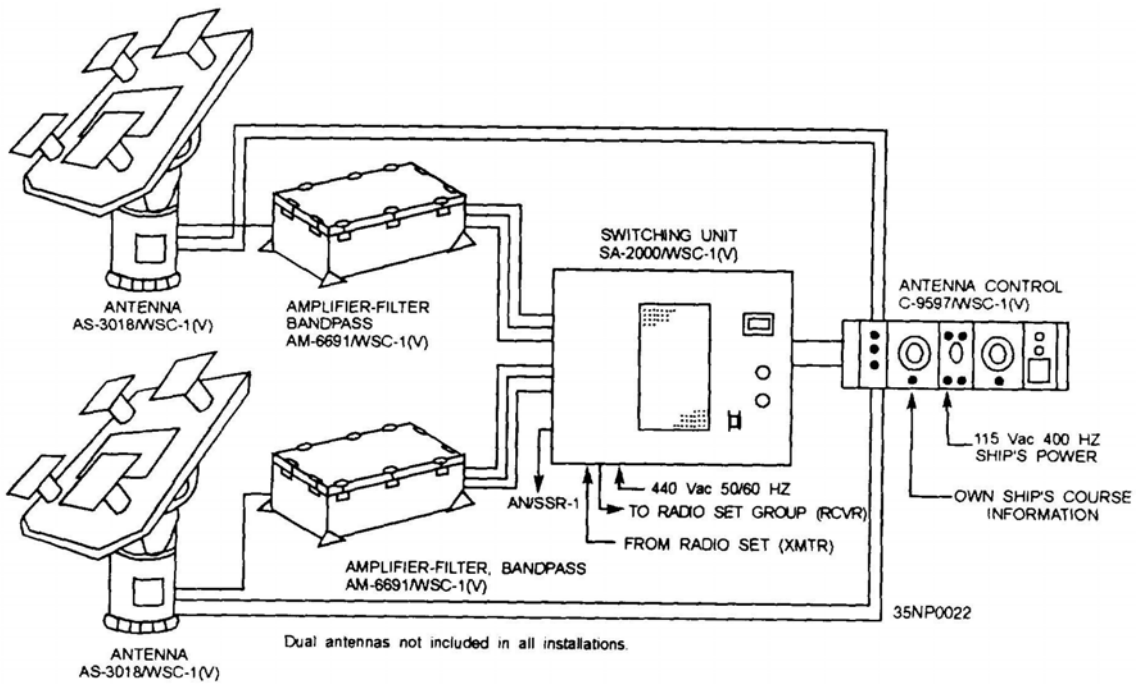

Figure 2-30.—OE-82/WSC-1(V) antenna group.

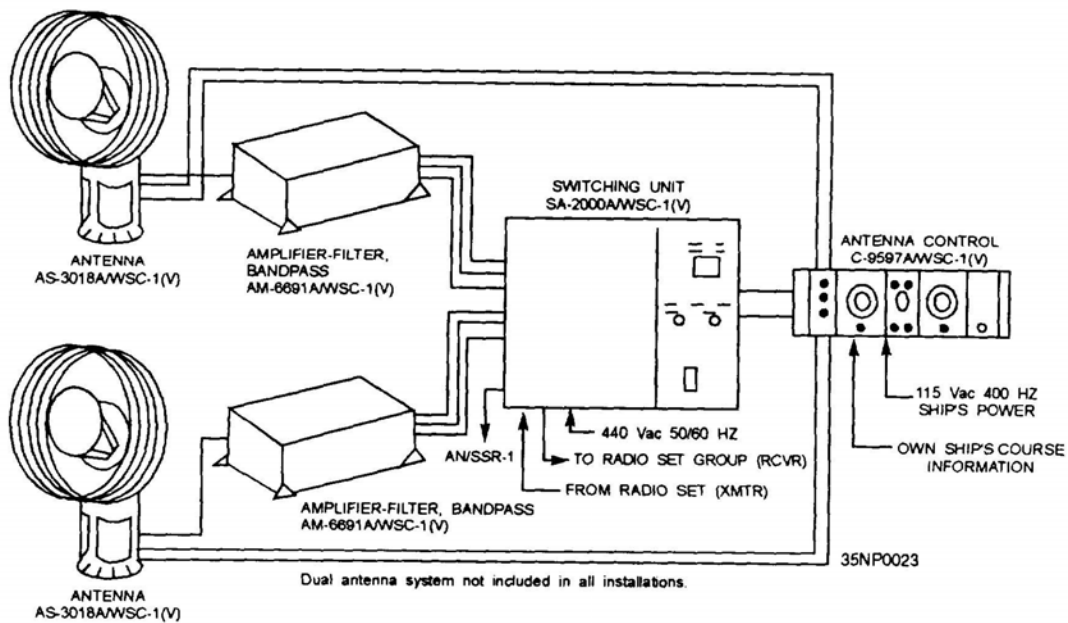

Figure 2-31.—OE-82C/WSC-1(V) antenna group.

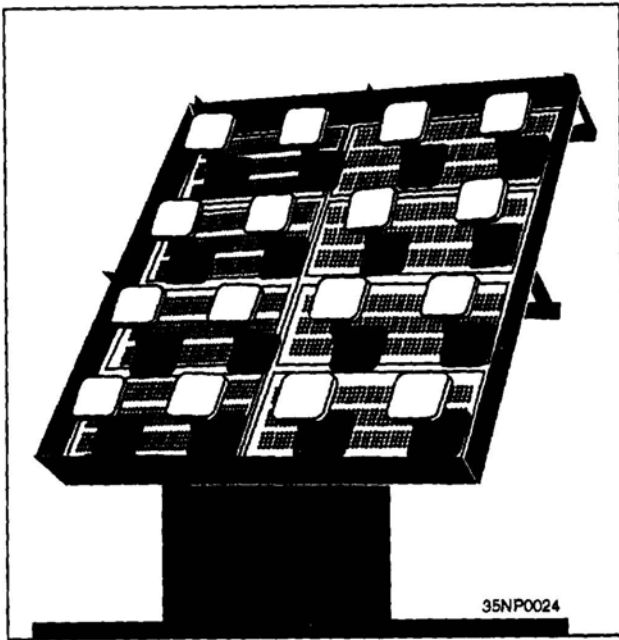

Figure 2-32.—OE-82A/WSC-1(V)/AN/WSC-5(V) shore station antenna.

the antenna weighs 2500 pounds and is 15 feet high, 10 feet wide, and 10 feet deep. The gain characteristics of this antenna are nominally 15 dB in transmit and 18 dB in receive.

#### ANDREW 58622 SHORE ANTENNA

The Andrew 58622 antenna (fig. 2-33) is a bifilar, 16-turn helical antenna right-hand circularly polarized, with gain varying between 11.2 and 13.2 dB in the 240-315 MKz frequency band. It has a 39-inch ground plate and is about 9 feet, 7 inches long. It can be adjusted manually in azimuth and elevation. This antenna is used at various shore installations, other than NCTAMS, for transmit and receive operations.

#### AN/WSC-6(V) SHF SATCOM ANTENNA

The antennas used on current shf SATCOM shipboard terminals are parabolic reflectors with cassegrain feeds. These antennas provide for LPI (low probability of intercept), with beamwidths less than 2.5 degrees (fig. 2-34). The reflectors are mounted on three-axis pedestals and provide autotracking of a beacon or communication signal by conical scanning

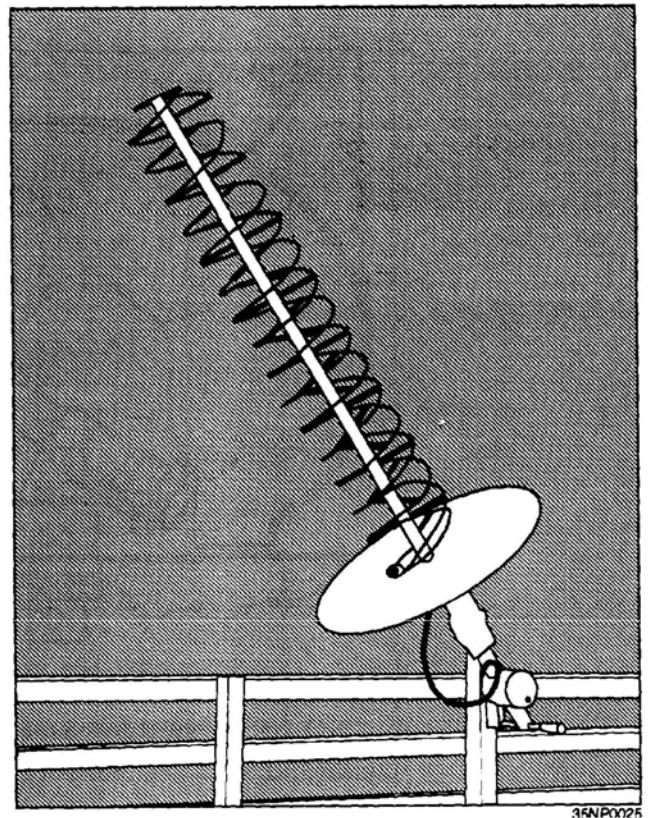

Figure 2-33.—Andrew 58622 shore antenna.

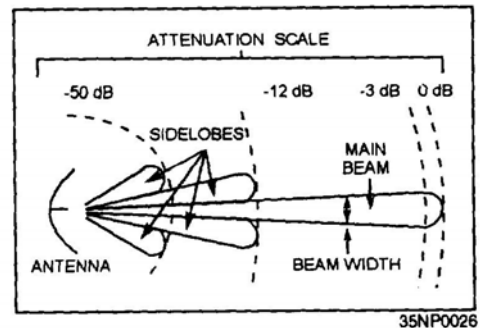

Figure 2-34.—AN/WSC-6(V) attenuation scale.

techniques. The antennas are radome enclosed and include various electronic components. Both a 7-foot model (fig. 2-35) and a 4-foot model (fig. 2-36) are operational in the fleet.

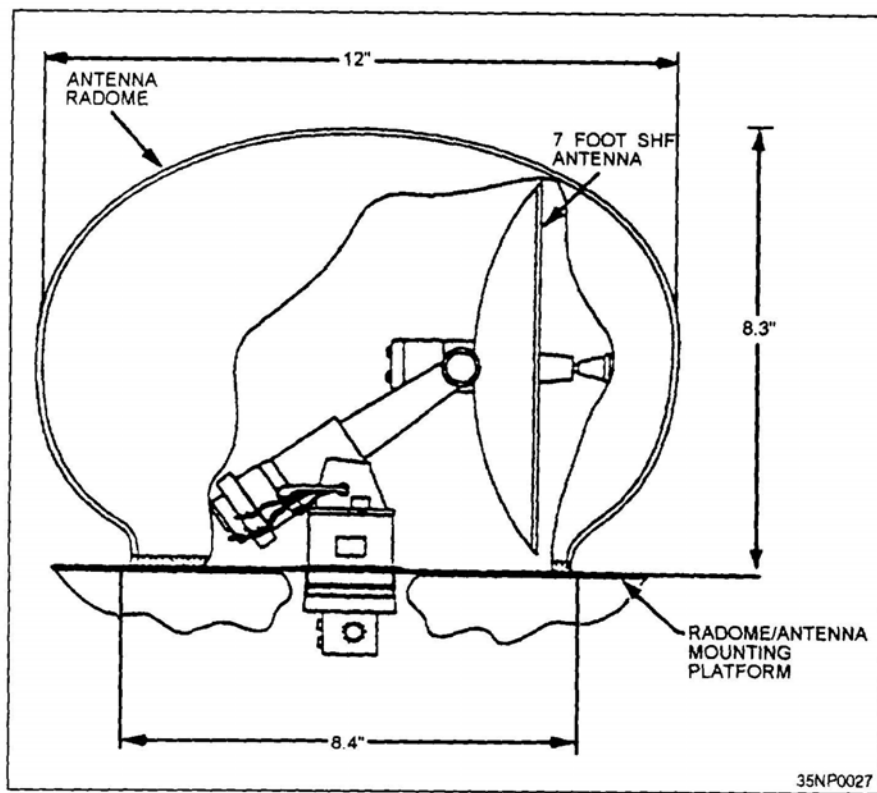

Figure 2-35.—Seven-foot shf SATCOM antenna.

## MATCHING NETWORKS

An antenna matching network consists of one or more parts (such as coils, capacitors, and lengths of transmission line) connected in series or parallel with the transmission line to reduce the standing wave ratio on the line. Matching networks are usually adjusted when they are installed and require no further adjustment for proper operation. Figure 2-37 shows a matching network outside of the antenna feedbox, with a sample matching network schematic.

Matching networks can also be built with variable components so they can be used for impedance matching over a range of frequencies. These networks are called antenna tuners.

Antenna tuners are usually adjusted automatically or manually each time the operating frequency is changed. Standard tuners are made with integral enclosures. Installation consists simply of mounting

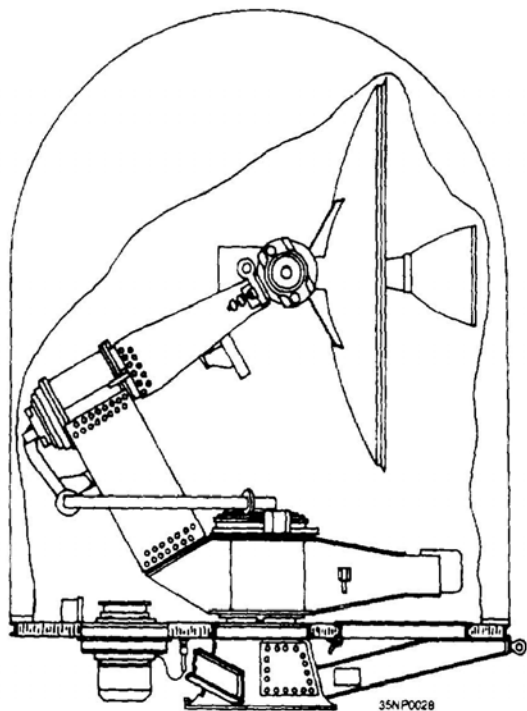

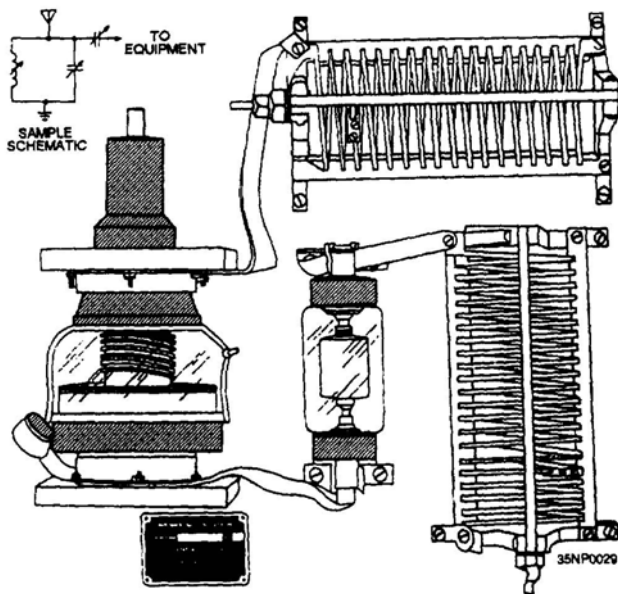

**Figure 2-37.—Matching network.**

the tuner, assembling the connections with the antenna and transmission line, and pressurizing the tuner, if necessary. Access must be provided to the pressure gauge and pressurizing and purging connections.

### ANTENNA TUNING

For every frequency in the frequency spectrum, there is an antenna that is perfect for radiating at that frequency. By that we mean that all of the power being transmitted from the transmitter to the antenna will be radiated into space. Unfortunately, this is the ideal and not the rule. Normally, some power is lost between the transmitter and the antenna. This power loss is the result of the antenna not having the perfect dimensions and size to radiate perfectly all of the power delivered to it from the transmitter. Naturally, it would be unrealistic to carry a separate antenna for every frequency that a communications center is capable of radiating; a ship would have to have millions of antennas on board, and that would be impossible.

To overcome this problem, we use ANTENNA TUNING to lengthen and shorten antennas electrically to better match the frequency on which we want to transmit. The rf tuner is connected electrically to the antenna and is used to adjust the apparent physical length of the antenna by electrical means. This simply

means that the antenna does not physically change length; instead, it is adapted electrically to the output frequency of the transmitter and “appears” to change its physical length. Antenna tuning is done by using antenna couplers, tuners, and multicouplers.

Antenna couplers and tuners are used to match a single transmitter or receiver to one antenna whereas antenna multicouplers are used to match more than one transmitter or receiver to o n e antenna for simultaneous operation. Some of the many antenna couplers that are in present use are addressed in the following paragraphs. For specific information on a particular coupler, refer to the appropriate equipment technical manual.

### Antenna Coupler Group AN/URA-38

Antenna Coupler Group AN/URA-38 is an automatic antenna tuning system intended primarily for use with the AN/URT-23(V) operating in the high-frequency range. The equipment also includes provisions for manual and semiautomatic tuning, making the system readily adaptable for use with other radio transmitters. The manual tuning feature is useful when a failure occurs in the automatic tuning circuitry. Tuning can also be done without the use of rf power (silent tuning). This method is useful in installations where radio silence must be maintained except for brief transmission periods.

The antenna coupler matches the impedance of a 15-, 25-, 28-, or 35-foot whip antenna to a 50-ohm transmission line, at any frequency in the 2-to 30-MHz range. When the coupler is used with the AN/URT-23(V), control signals from the associated antenna coupler control unit automatically tune the coupler’s matching network in less than 5 seconds. During manual and silent operation, the operator uses the controls mounted on the antenna coupler control unit to tune the antenna. A low-power (less than 250 watts) cw signal is required for tuning. Once tuned, the CU 938A/URA-38 is capable of handling 1000 watts PEP.

### Antenna Coupler Groups AN/SRA-56, -57, and -58

Antenna coupler groups AN/SRA-56, -57, and -58 are designed primarily for shipboard use. Each

coupler group permits several transmitters to operate simultaneously into a single, associated, broadband antenna, thus reducing the total number of antennas required in the limited space aboard ship.

These antenna coupler groups provide a coupling path of prescribed efficiency between each transmitter and the associated antenna. They also provide isolation between transmitters, tunable bandpass filters to suppress harmonic and spurious transmitter outputs, and matching networks to reduce antenna impedances.

The three antenna coupler groups (AN/SRA-56, -57, -58) are similar in appearance and function, but they differ in frequency ranges. Antenna coupler group AN/SRA-56 operates in the 2- to 6-MHz frequency range. The AN/SRA-57 operates from 4 to 12 MHz, and the AN/SRA-58 operates from 10 to 30 MHz. When more than one coupler is used in the same frequency range, a 15 percent frequency separation must be maintained to avoid any interference.

### Antenna Coupler Group AN/SRA-33

Antenna coupler group AN/SRA-33 operates in the uhf (225-400 Mhz) frequency range. It provides isolation between as many as four transmitter and receiver combinations operating simultaneously into a common uhf antenna without degrading operation. The AN/SRA-33 is designed for operation with shipboard radio set AN/WSC-3. The AN/SRA-33 consists of four antenna couplers (CU-1131/SRA-33 through CU-1134/SRA-33), a control power supply C-4586/SRA-33, an electronic equipment cabinet CY-3852/SRA-33, and a set of special-purpose cables.

### OA-9123/SRC

The OA-9123/SRC multicoupler enables up to four uhf transceivers, transmitters, or receivers to operate on a common antenna. The multicoupler provides low insertion loss and highly selective filtering in each of the four ports. The unit is interface compatible with the channel select control signals from radio sets AN/WSC-3(V) (except (V)1). The unit is self-contained and is configured to fit into a standard 19-inch open equipment rack.

The OA-9123/SRC consists of a cabinet assembly, control power supply assembly, and four identical filter assemblies. This multicoupler is a state-of-the-art replacement for the AN/SRA-33 and only requires about half of the space.

## RECEIVING ANTENNA DISTRIBUTION SYSTEMS

Receiving antenna distribution systems operate at low power levels and are designed to prevent multiple signals from being received. The basic distribution system has several antenna transmission lines and several receivers, as shown in figure 2-38. The system includes two basic patch panels, one that terminates the antenna transmission lines, and the other that terminates the lines leading to the receivers. Thus, any antenna can be patched to any receiver via patch cords.

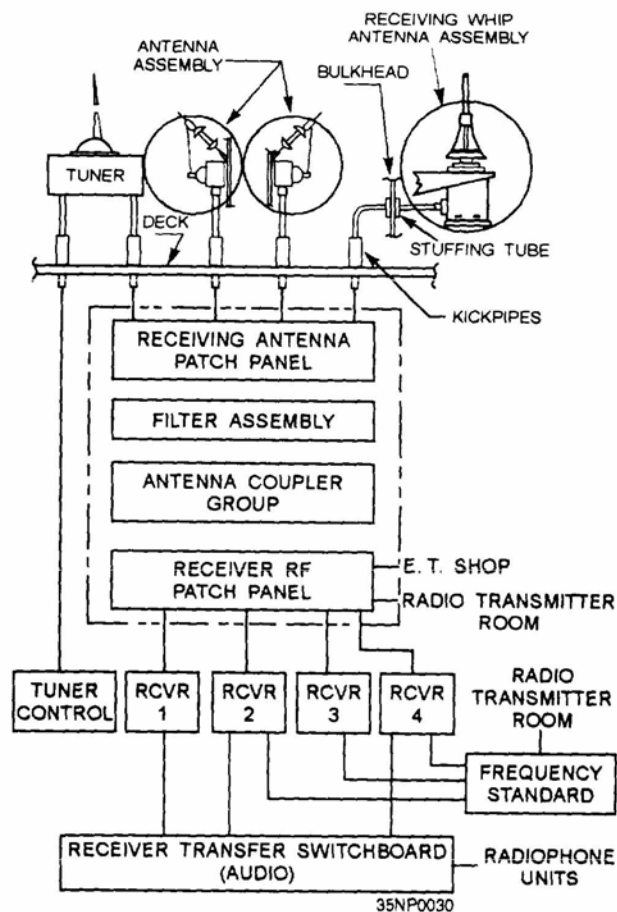

Figure 2-38.—Receive signal distribution system.

Some distribution systems will be more complex. That is, four antennas can be patched to four receivers, or one antenna can be patched to more than one receiver via the multicouplers.

### RECEIVING MULTICOUPLER AN/SRA-12

The AN/SRA-12 filter assembly multicoupler provides seven radio frequency channels in the 14-kHz to 32-MHz frequency range. Any of these channels may be used independently of the other channels, or they may operate simultaneously. Connections to the receiver are made by coaxial patch cords, which are short lengths of cable with a plug attached to each end.

### ANTENNA COUPLER GROUPS AN/SRA-38, AN/SRA-39, AN/SRA-40, AN/SRA-49, AN/SRA- 49A, and AN/SRA-50

These groups are designed to connect up to 20 mf and hf receivers to a single antenna, with a highly selective degree of frequency isolation. Each of the six coupler groups consists of 14 to 20 individual antenna couplers and a single-power supply module, all are slide-mounted in a special electronic equipment rack. An antenna input distribution line termination (dummy load) is also supplied. In addition, there are provisions for patching the outputs from the various antenna couplers to external receivers.

## RADAR ANTENNAS

Radar antennas are usually directional antennas that radiate energy in one lobe or beam. The two most important characteristics of directional antennas are directivity and power gain. Most radar systems use parabolic antennas. These antennas use parabolic reflectors in different variations to focus the radiated energy into a desired beam pattern.

While most radar antennas are parabolic, other types such as the corner reflector, the broadside array, and horn radiators may also be used.

### PARABOLIC REFLECTORS

To understand why parabolic reflectors are used for most radar antennas, you need to understand how

radio waves behave. A point source, such as an omnidirectional antenna produces a spherical radiation pattern, or spherical wavefront. As the sphere expands, the energy contained in a given surface area decreases rapidly. At a relatively short distance from the antenna, the energy level is so small that its reflection from a target would be useless in a radar system.

A solution to this problem is to form the energy into a PLANE wavefront, In a plane wavefront, all of the energy travels in the same direction, thus providing more energy to reflect off of a target. To concentrate the energy even further, a parabolic reflector is used to shape the plane wavefront's energy into a beam of energy. This concentration of energy provides a maximum amount of energy to be reflected off of a target, making detection of the target much more probable.

How does the parabolic reflector focus the radio waves? Radio waves behave much as light waves do. Microwaves travel in straight lines as do light rays. They may be focused or reflected, just as light rays may be. In figure 2-39, a point-radiation source is placed at the focal point F. The field leaves this antenna with a spherical wavefront. As each part of the wavefront moving toward the reflector reaches the reflecting surface, it is shifted 180 degrees in phase and sent outward at angles that cause all parts of the field to travel in parallel paths. Because of the shape of a parabolic surface, all paths from F to the reflector and back to line XY are the same length. Therefore, all parts of the field arrive at line XY at the same time after reflection.

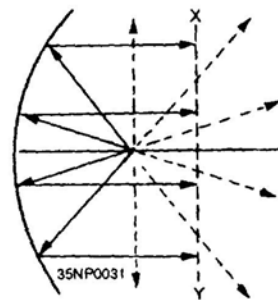
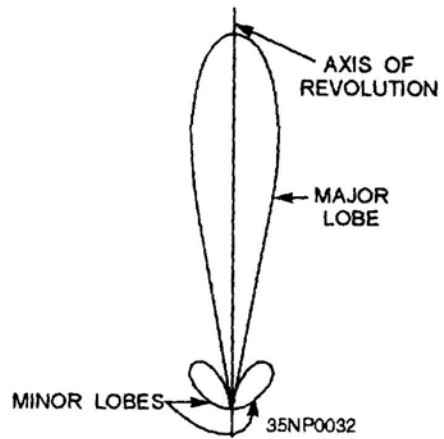

Figure 2-39.—Parabolic reflector radiation.

Energy that is not directed toward the paraboloid (dotted lines in fig. 2-39) has a wide-beam characteris

tic that would destroy the narrow pattern from the parabolic reflector. This destruction is prevented by the use of a hemispherical shield (not shown) that directs most of what would otherwise be spherical radiation toward the parabolic surface. Without the shield, some of the radiated field would leave the radiator directly, would not be reflected, and would serve no useful purpose. The shield makes the beam sharper, and concentrates the majority of the power in the beam. The same results can be obtained by using either a parasitic array to direct the radiated field back to the reflector, or a feed horn pointed at the paraboloid.



**Figure 2-40.—Parabolic radiation pattern.**

The radiation pattern of the paraboloid contains a major lobe, which is directed along the axis of the paraboloid, and several minor lobes, as shown in figure 2-40. Very narrow beams are possible with this type of reflector. View A of figure 2-41 illustrates the parabolic reflector.

produce differently shaped beams. View B of figure 2-41 shows a horizontally truncated, or vertically shortened, paraboloid. This type of reflector is designed to produce a beam that is narrow horizontally but wide vertically. Since the beam is wide vertically, it will detect aircraft at different altitudes without changing the tilt of the antenna. It also works well for surface search radars to overcome the pitch and roll of the ship.

**Truncated Paraboloid**

While the complete parabolic reflector produces a pencil-shaped beam, partial parabolic reflectors

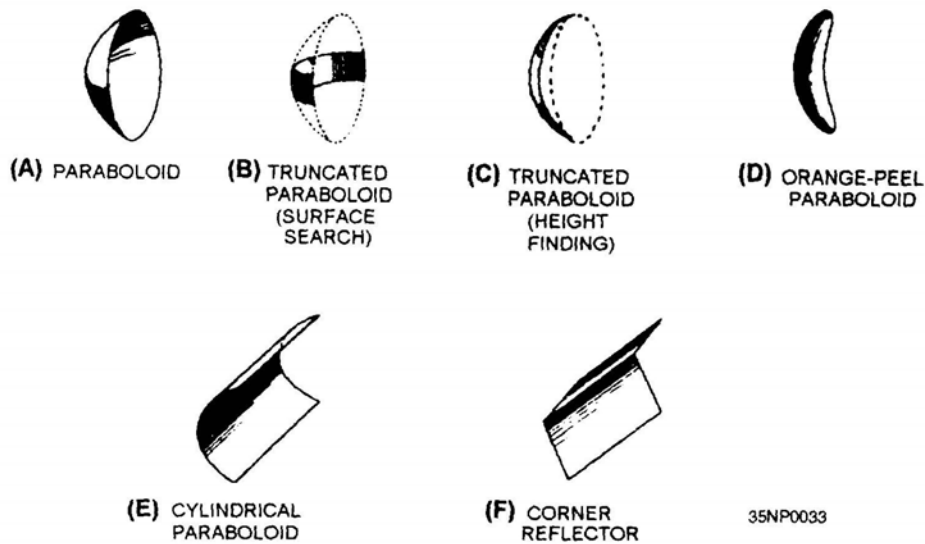

**Figure 2-41.—Reflector shapes.**



The truncated paraboloid reflector may be used in height-finding systems if the reflector is rotated 90 degrees, as shown in view C of figure 2-41. This type of reflector produces a beam that is wide horizontally but narrow vertically. The beam pattern is spread like a horizontal fan. Such a fan-shaped beam can be used to determine elevation very accurately.

### **Orange-Peel Paraboloid**

A section of a complete circular paraboloid, often called an ORANGE-PEEL REFLECTOR because of its shape, is shown in view D of figure 2-41. Since the reflector is narrow in the horizontal plane and wide in the vertical, it produces a beam that is wide in the horizontal plane and narrow in the vertical. In shape, the beam resembles a huge beaver tail. This type of antenna system is generally used in height-finding equipment.

### **Cylindrical Paraboloid**

When a beam of radiated energy noticeably wider in one cross-sectional dimension than in the other is desired, a cylindrical paraboloid section approximating a rectangle can be used. View E of figure 2-41 illustrates this antenna. A parabolic cross section is in one dimension only; therefore, the reflector is directive in one plane only. The cylindrical paraboloid reflector is either fed by a linear array of dipoles, a slit in the side of a waveguide, or by a thin waveguide radiator. Rather than a single focal point, this type of reflector has a series of focal points forming a straight line. Placing the radiator, or radiators, along this focal line produces a directed beam of energy. As the width of the parabolic section is changed, different beam shapes are produced. This type of antenna system is used in search systems and in ground control approach (gca) systems.

### **CORNER REFLECTOR**

The corner-reflector antenna consists of two flat conducting sheets that meet at an angle to form a corner, as shown in view F of figure 2-41. This reflector is normally driven by a half-wave radiator located on a line that bisects the angle formed by the sheet reflectors.

### **BROADSIDE ARRAY**

Desired beam widths are provided for some vhf radars by a broadside array, such as the one shown in figure 2-42. The broadside array consists of two or more half-wave dipole elements and a flat reflector. The elements are placed one-half wavelength apart and parallel to each other. Because they are excited in phase, most of the radiation is perpendicular or broadside to the plane of the elements. The flat reflector is located approximately one-eighth wavelength behind the dipole elements and makes possible the unidirectional characteristics of the antenna system.

### **HORN RADIATORS**

Horn radiators, like parabolic reflectors, may be used to obtain directive radiation at microwave frequencies. Because they do not involve resonant elements, horns have the advantage of being usable over a wide frequency band.

The operation of a horn as an electromagnetic directing device is analogous to that of acoustic horns. However, the throat of an acoustic horn usually has dimensions much smaller than the sound wavelengths for which it is used, while the throat of the electromagnetic horn has dimensions that are comparable to the wavelength being used.

Horn radiators are readily adaptable for use with waveguides because they serve both as an impedance-

matching device and as a directional radiator. Horn radiators may be fed by coaxial or other types of lines.

**Figure 2-42.—Broadside array.**

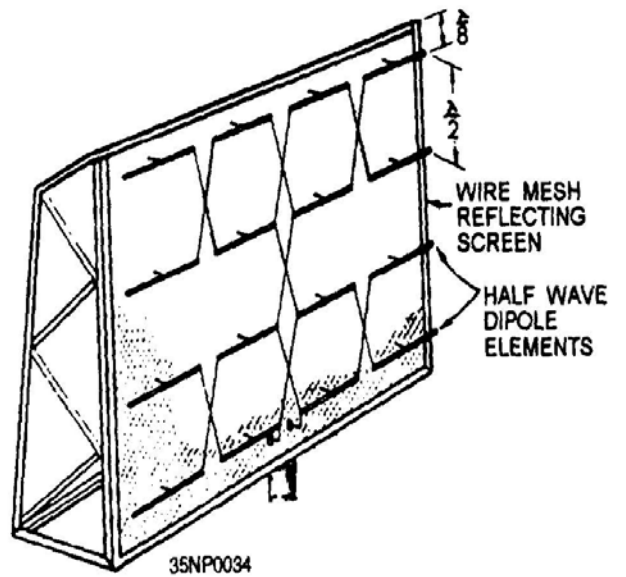

Horns are constructed in a variety of shapes as illustrated in figure 2-43. The shape of the horn and the dimensions of the length and mouth largely determine the field-pattern shape. The ratio of the horn length to mouth opening size determines the beam angle and, thus, the directivity. In general, the larger the opening of the horn, the more directive is the resulting field pattern.

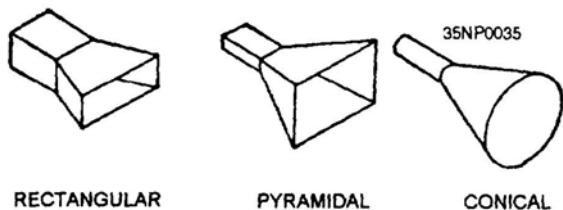

Figure 2-43.—Horn radiators.

### FEEDHORNS

A waveguide horn, called a FEEDHORN, may be used to feed energy into a parabolic dish. The directivity of this feedhorn is added to that of the parabolic dish. The resulting pattern is a very narrow and concentrated beam. In most radars, the feedhorn is covered with a window of polystyrene fiberglass to prevent moisture and dirt from entering the open end of the waveguide.

One problem associated with feedhorns is the SHADOW introduced by the feedhorn if it is in the path of the beam. (The shadow is a dead spot directly in front of the feedhorn.) To solve this problem the feedhorn can be offset from center. This location change takes the feedhorn out of the path of the rf beam and eliminates the shadow. An offset feedhorn is shown in figure 2-44.

### RADAR SYSTEMS

Now that you have a basic understanding of how radar antennas operate, we will introduce you to a few of the radar systems currently in use.

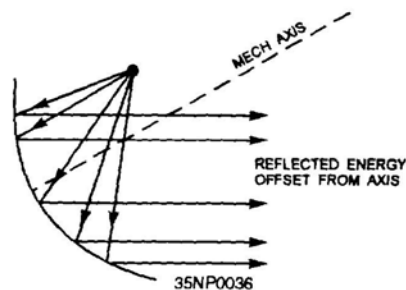

Figure 2-44.—Offset feedhorn.

### AN/GPN-27(ASR-8) AIR SURVEILLANCE RADAR

The AN/GPN-27(ASR-8) (fig. 2-45) antenna radiates a beam 1.5 degrees in azimuth and shaped in elevation to produce coverage of up to approximately 32 degrees above the horizon. This provides a maplike presentation of aircraft within 55 nautical miles of an airport terminal. The antenna azimuth

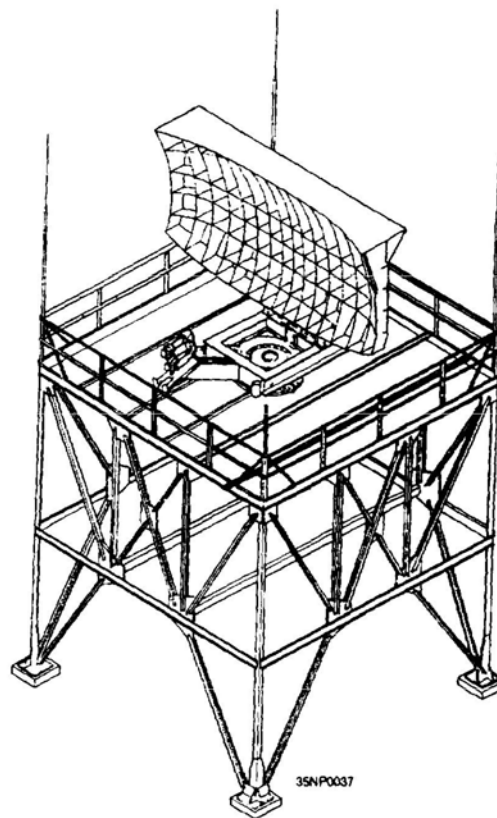

Figure 2-45.—AN/GPN-27(ASR-8) air surveillance radar.

pulse generator (APG), located in the rotary joint, transmits to the radar indicator azimuth information corresponding to beam direction. Polarization of the radiated energy can be remotely switched to either linear or circular polarization. The reflector has a modified parabolic shape designed to produce an approximately cosecant squared beam in the elevation plane. The reflector surface, covered with expanded aluminum screen, is 16.1 feet wide and 9 feet high. The antenna feedhorn, which mounts on the polarizer, provides impedance matching between the waveguide system and free space, and produces the desired feed pattern to illuminate the reflector. A radome over the horn aperture excludes moisture and foreign matter, and provides a pressure seal.

### AS-3263/SPS-49(V)

The AS-3263/SPS-49(V) antenna (fig. 2-46) consists of three major sections: the antenna base and

pedestal assembly, the feedhorn and feedhorn support boom, and the reflector assembly.

The base assembly provides a surface for mounting the antenna to the ship. It also contains the azimuth drive gearbox. The gearbox is driven by the azimuth drive motor, which drives the pedestal in azimuth through a pinion gear mated to a ring gear located at the bottom of the cone-shaped pedestal assembly. The azimuth drive circuits rotate the antenna through 360 degrees at speeds of 6 rpm and 12 rpm.

The reflector and the feedhorn support boom are mounted on a trunnion, allowing the elevation angle of the rf beam to be controlled by a jackscrew located behind the reflector. The jackscrew is rotated by the elevation drive gearbox, which is connected to two dc motors. The rf energy to the feedhorn is routed through elevation and azimuth rotary joints located within the pedestal.

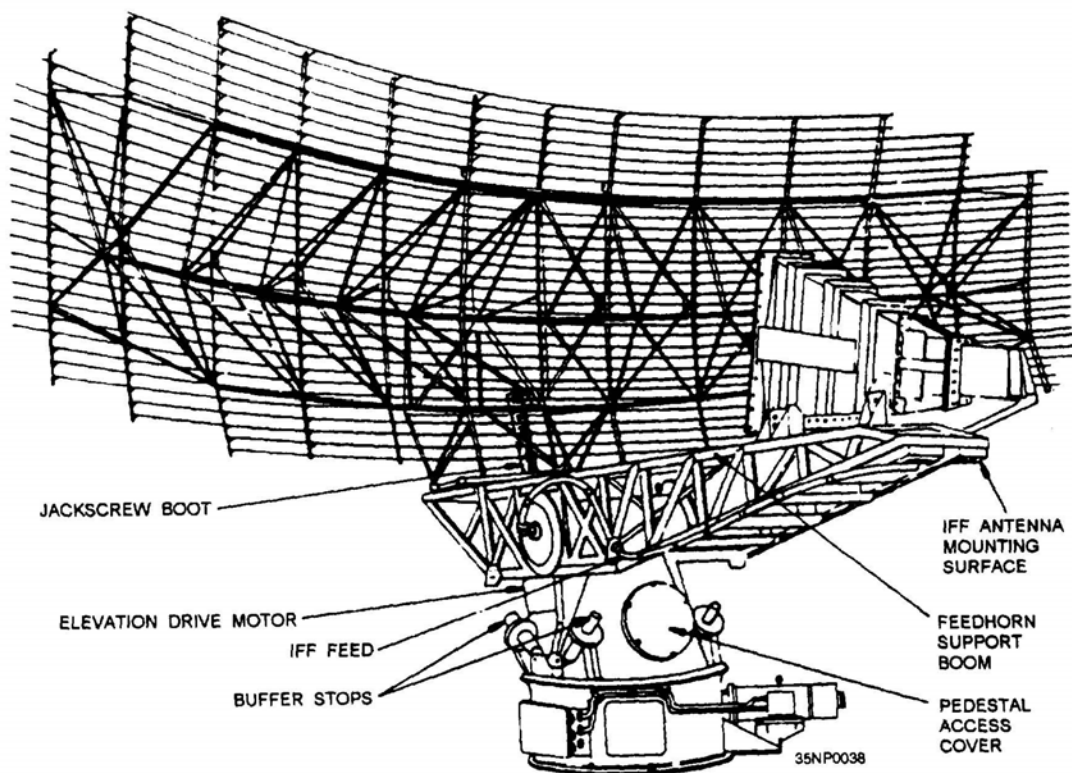

Figure 2-46.—AS-3263/SPS-49(V) antenna.

The reflector is 24 feet wide and has a double-curved surface composed of a series of horizontal members that form a reflecting surface for the horizontally polarized C-band energy. The antenna has a 28-dB gain, with a beamwidth of 9 degrees minimum vertically and approximately 3.3 degrees horizontally. Antenna roll and pitch stabilization limits are plus or minus 25 degrees, Stabilization accuracy is plus or minus 1 degree with the horizontal plane.

The antenna is equipped with a safety switch located near the antenna pedestal area. The safety switch disables the azimuth and elevation functions in the antenna and the radiate function in the transmitter to provide protection for personnel working on the antenna.

### OE-172/SPS-55

The OE-172/SPS-55 antenna group consists of the antenna and the antenna pedestal. The antenna group is mast-mounted by means of four bolt holes on the base of the pedestal.

The antenna consists of two waveguide slotted arrays mounted back-to-back. One array provides linear polarization, while the other provides circular polarization. The array used is selected by means of a remotely controlled waveguide switch located on the pedestal. Linear polarization is used for most conditions. Circular polarization is used to reduce return echoes from precipitation. Each antenna forms a fan beam that is narrow in the azimuth plane and moderately broad in the elevation plane.

Figure 2-47 shows a cross-section of the SPS-55 antenna. During transmission, the rf signal enters the antenna through a feed waveguide and then enters a feed manifold region of 80 periodic narrow-wall slots. The slots are skewed in angle and alternated in direction of skew. They are separated by approximately one-half wavelength, resulting in broadside radiation into the sectoral horn region of the antenna. The horizontally polarized radiation from the manifold travels in the horn region toward the aperture, where it encounters an array of vertical sheet metal slats.

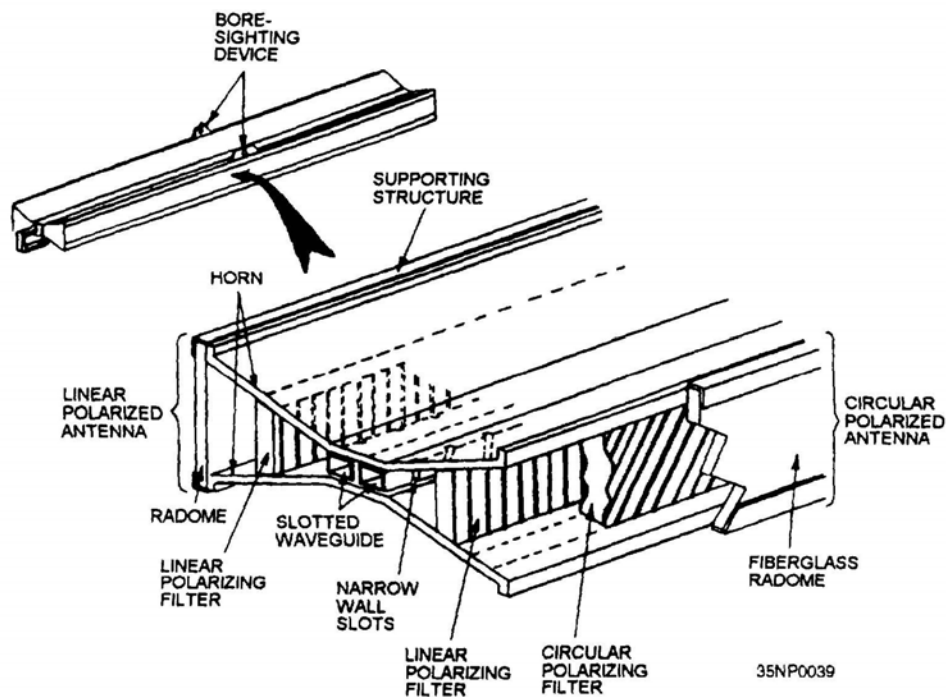

Figure 2-47.—SPS-55 antenna cross section.

This array is a polarizing filter, which ensures that only horizontally polarized energy travels from the horn region. The antenna scans at a rate of 16 rpm and produces an absolute gain of 31 dB at midband.

### AN/SPN-35A AIRCRAFT CONTROL APPROACH RADAR

The AN/SPN-35A (fig 2-48) is a carrier-controlled-approach (CCA) radar set used for precision landing approaches during adverse weather conditions. The radar displays both azimuth and elevation data, which enables the radar operator to direct aircraft along a predetermined glide path and

azimuth course line to a transition point approximately 2 miles from the ramp of the flight deck.

The azimuth antenna, AS-1292/TPN-8, functions in the azimuth rf line for radiation and reception of X-band rf pulses. The azimuth antenna comprises a truncated paraboloid-type reflector with an offset feedhorn and a polarizer assembly that provides remote-controlled selection of either horizontal or circular polarization. The antenna is located above the azimuth drive assembly on the stabilized yoke. The azimuth drive can rotate the antenna in either 360 degrees or in limited-sector modes of operation in the horizontal plane.

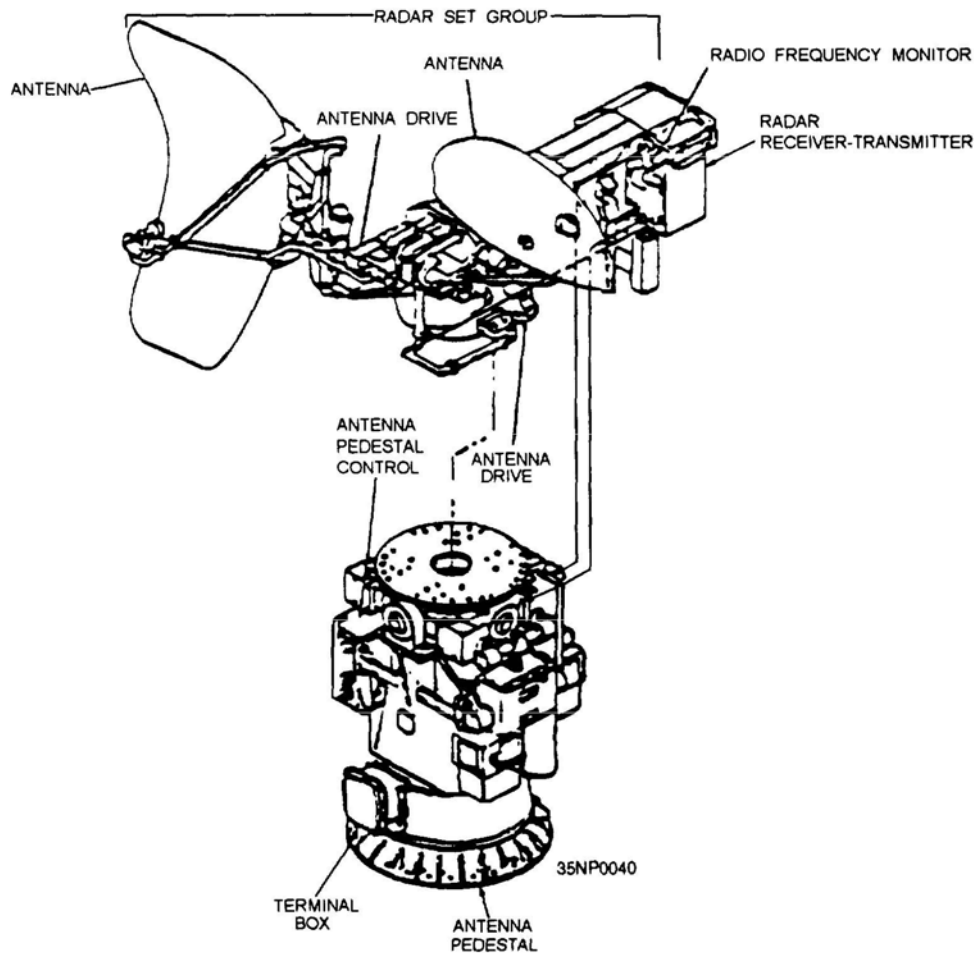

Figure 2-48.—AN/SPN-35A aircraft control approach radar.

The elevation antenna, AS-1669/SPN-35, is a truncated paraboloid-type reflector with a dual-channel feedhorn and a polarizer assembly providing monopulse-type radiation and reception of X-band rf pulses. The horizontal shape of the laminated fiberglass reflector is cosecant. The dual-channel feedhorn and polarizer are fixed in circular polarization by an external grid device. The elevation antenna is stabilized-yoke mounted on the elevation drive assembly adjacent to the azimuth antenna. The elevation drive provides the required motion for the elevation antenna and locks electrically with the search drive when the radar set operates in the precision mode.

The radar operates in three modes, final, surveillance, and simultaneous, with each antenna acting independently. In the final (precision) mode, the azimuth antenna scans a 30-degree sector (60-degree sector optional) while the elevation antenna scans a 10-degree sector (35-degree sector optional). In the surveillance mode the azimuth antenna rotates through the full 360-degree search pattern at 16 rpm while the elevation antenna scans a 10-degree sector. In the simultaneous mode, the azimuth antenna rotates through the full 360-degree search pattern in 60-degree increments while the elevation antenna scans a 10-degree sector. The data rate in this mode is approximately 16 azimuth sweeps and 24 elevation sweeps every 60 seconds.

The antenna pedestal control stabilizes the azimuth and elevation antennas for plus or minus 3 degrees of pitch and plus or minus 10 degrees of roll.

### **RF SAFETY PRECAUTIONS**

Although radio frequency emissions are usually harmless, there are still certain safety precautions you should follow whenever you are near high-power rf sources. Normally, electromagnetic radiation from transmission lines and antennas isn't strong enough to electrocute personnel. However, it may lead to other accidents and can compound injuries. Voltages may be induced into metal objects both above and below ground, such as wire guys, wire cable, hand rails, and ladders. If you come into contact with these objects, you may receive a shock or an rf burn. The shock can cause you to jump involuntarily, to fall into nearby

equipment, or, when working aloft, to fall from the elevated work area. Take care to ensure that all transmission lines or antennas are de-energized before working on or near them.

When working aloft aboard ship, be sure to use a working aloft chit. This will ensure that all radiators, not only those on your own ship but also those nearby are secured while you are aloft.

**ALWAYS** obey rf radiation warning signs and keep a safe distance from radiating antennas. The six types of warning signs for rf radiation hazards are shown in figure 2-49.

The two primary safety concerns associated with rf fields are rf burns and injuries caused by dielectric heating.

### **RF BURNS**

Close or direct contact with rf transmission lines or antennas may result in rf burns caused by induced voltages. These burns are usually deep, penetrating, third-degree burns. To heal properly, rf burns must heal from the inside toward the skin's surface. Do **NOT** take rf burns lightly. To prevent infection, you must give proper attention to **ALL** rf burns, including the small pinhole burns. **ALWAYS** seek treatment for any rf burn or shock and report the incident to your supervisor so appropriate action can be taken to correct the hazard.

### **DIELECTRIC HEATING**

While the severity of rf burns may vary from minor to major, burns or other damage done by **DIELECTRIC HEATING** may result in long-term injury, or even death. Dielectric heating is the heating of an insulating material caused by placing it in a high-frequency electric field. The heat results from the rapid reversal of molecular polarization dielectric material.

When a human is in an rf field, the body acts as the dielectric. If the power in the rf field exceeds 10 milliwatts per centimeter, the individual will have a noticeable rise in body temperature. Basically, the body is "cooking" in the rf field. The vital organs



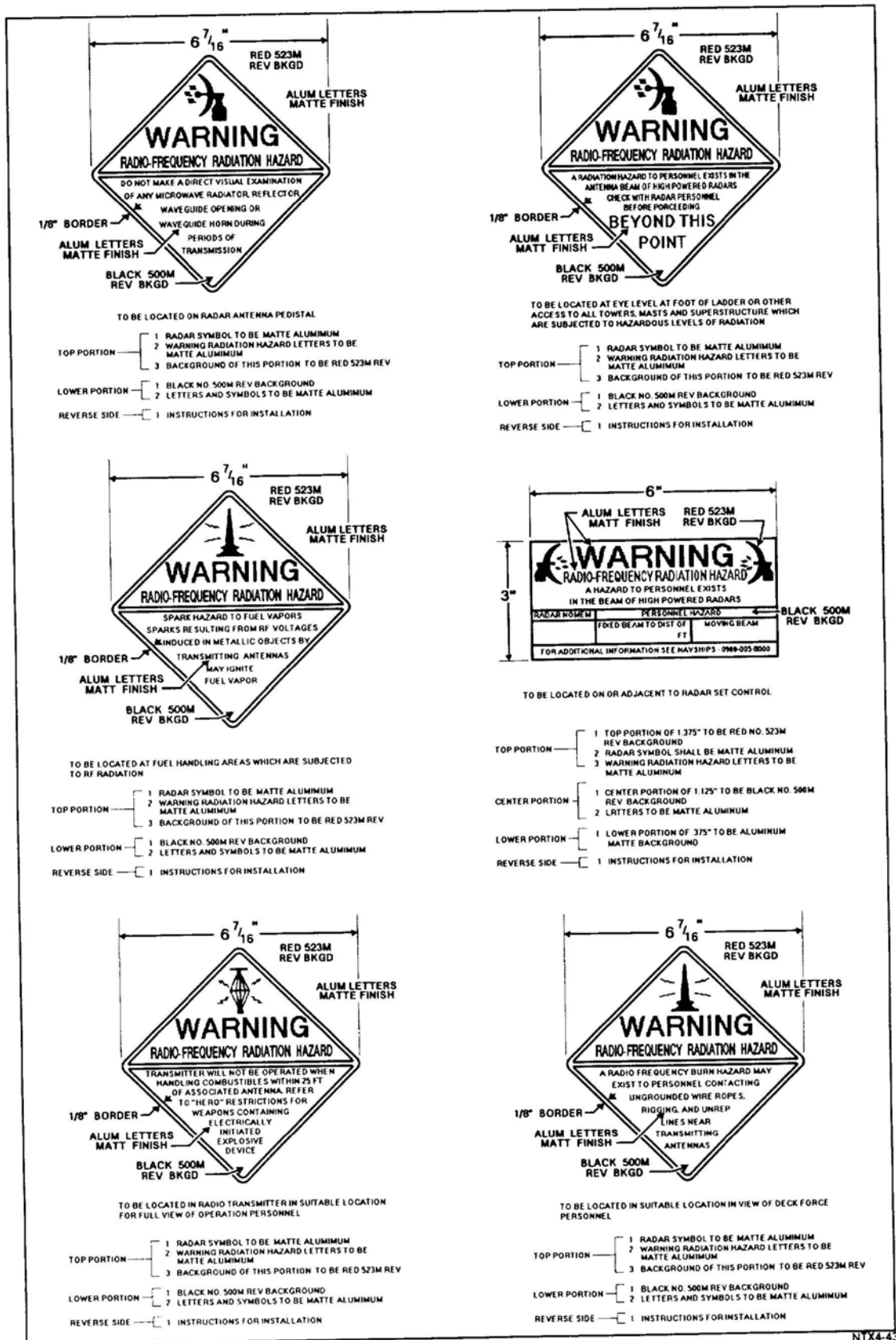

Figure 2-49.—Rf radiation warning signs

of the body are highly susceptible to dielectric heating. The eyes are also highly susceptible to dielectric heating. Do NOT look directly into devices radiating rf energy. Remember, rf radiation can be dangerous. For your own safety, you must NOT stand directly in the path of rf radiating devices.

## **PRECAUTIONS    WHEN    WORKING ALOFT**

As we mentioned earlier, it is extremely important to follow all safety precautions when working aloft. Before you work on an antenna, ensure that it is tagged out properly at the switchboard to prevent it from becoming operational. Always be sure to secure the motor safety switches for rotating antennas. Have

the switches tagged and locked open before you begin working on or near the antenna.

When working near a stack, draw and wear the recommended oxygen breathing apparatus. Among other toxic substances, stack gas contains carbon monoxide. Carbon monoxide is too unstable to build up to a high concentration in the open, but prolonged exposure to even small quantities is dangerous.

For more detailed information concerning the dangers and hazards of rf radiation, refer to the NAVELEX technical manual, *Electromagnetic Radiation Hazards*. NAVELEX 0967-LP-624-6010.

This completes chapter 2. In chapter 3, we will discuss transmission lines and waveguides.

## CHAPTER 3

# INTRODUCTION TO TRANSMISSION LINES AND WAVEGUIDES

A TRANSMISSION LINE is a device designed to guide electrical energy from one point to another. It is used, for example, to transfer the output rf energy of a transmitter to an antenna. This energy will not travel through normal electrical wire without great losses. Although the antenna can be connected directly to the transmitter, the antenna is usually located some distance away from the transmitter. On board ship, the transmitter is located inside a radio room, and its associated antenna is mounted on a mast. A transmission line is used to connect the transmitter and the antenna.

The transmission line has a single purpose for both the transmitter and the antenna. This purpose is to transfer the energy output of the transmitter to the antenna with the least possible power loss. How well this is done depends on the special physical and electrical characteristics (impedance and resistance) of the transmission line.

### TRANSMISSION LINE THEORY

The electrical characteristics of a two-wire transmission line depend primarily on the construction of the line. The two-wire line acts like a long capacitor. The change of its capacitive reactance is noticeable as the frequency applied to it is changed. Since the long conductors have a magnetic field about them when electrical energy is being passed through them, they also exhibit the properties of inductance. The values of inductance and capacitance presented depend on the various physical factors that we discussed earlier. For example, the type of line used, the dielectric in the line, and the length of the line must be considered. The effects of the inductive and capacitive reactance of the line depend on the frequency applied. Since no dielectric is perfect, electrons manage to move from one conductor to the other through the dielectric. Each type of two-wire transmission line also has a conductance value. This conductance value represents the value of the current

flow that may be expected through the insulation. If the line is uniform (all values equal at each unit length), then one small section of the line may represent several feet. This illustration of a two-wire transmission line will be used throughout the discussion of transmission lines; but, keep in mind that the principles presented apply to all transmission lines. We will explain the theories using LUMPED CONSTANTS and DISTRIBUTED CONSTANTS to further simplify these principles.

### LUMPED CONSTANTS

A transmission line has the properties of inductance, capacitance, and resistance just as the more conventional circuits have. Usually, however, the constants in conventional circuits are lumped into a single device or component. For example, a coil of wire has the property of inductance. When a certain amount of inductance is needed in a circuit, a coil of the proper dimensions is inserted. The inductance of the circuit is lumped into the one component. Two metal plates separated by a small space, can be used to supply the required capacitance for a circuit. In such a case, most of the capacitance of the circuit is lumped into this one component. Similarly, a fixed resistor can be used to supply a certain value of circuit resistance as a lumped sum. Ideally, a transmission line would also have its constants of inductance, capacitance, and resistance lumped together, as shown in figure 3-1. Unfortunately, this is not the case. Transmission line constants are as described in the following paragraphs.

### DISTRIBUTED CONSTANTS

Transmission line constants, called distributed constants, are spread along the entire length of the transmission line and cannot be distinguished separately. The amount of inductance, capacitance, and resistance depends on the length of the line, the size of the conducting wires, the spacing between the

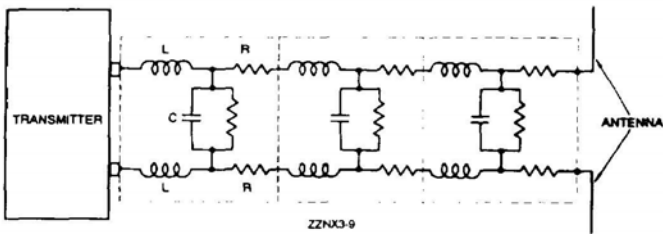

Figure 3-1.—Two-wire transmission line.

wires, and the dielectric (air or insulating medium) between the wires. The following paragraphs will be useful to you as you study distributed constants on a transmission line.

### Inductance of a Transmission Line

When current flows through a wire, magnetic lines of force are set up around the wire. As the current increases and decreases in amplitude, the field around the wire expands and collapses accordingly. The energy produced by the magnetic lines of force collapsing back into the wire tends to keep the current flowing in the same direction. This represents a certain amount of inductance, which is expressed in microhenrys per unit length. Figure 3-2 illustrates the inductance and magnetic fields of a transmission line.

### Capacitance of a Transmission Line

Capacitance also exists between the transmission line wires, as illustrated in figure 3-3. Notice that the two parallel wires act as plates of a capacitor and that the air between them acts as a dielectric. The capacitance between the wires is usually expressed in picofarads per unit length. This electric field between the wires is similar to the field that exists between the two plates of a capacitor.

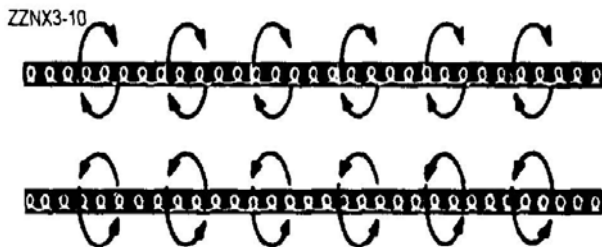

Figure 3-3.—Distributed capacitance.

### Resistance of a Transmission Line

The transmission line shown in figure 3-4 has electrical resistance along its length. This resistance is usually expressed in ohms per unit length and is shown as existing continuously from one end of the line to the other.



Figure 3-4.—Distributed resistance.

### Leakage Current

Since any dielectric, even air, is not a perfect insulator, a small current known as LEAKAGE CURRENT flows between the two wires. In effect, the insulator acts as a resistor, permitting current to pass between the two wires. Figure 3-5 shows this leakage path as resistors in parallel connected between the two lines. This property is called CONDUCTANCE (G) and is the opposite of resistance. Conductance in transmission lines is expressed as the reciprocal of resistance and is usually given in micromhos per unit length.

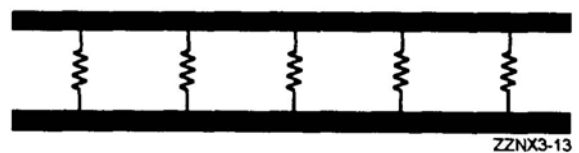
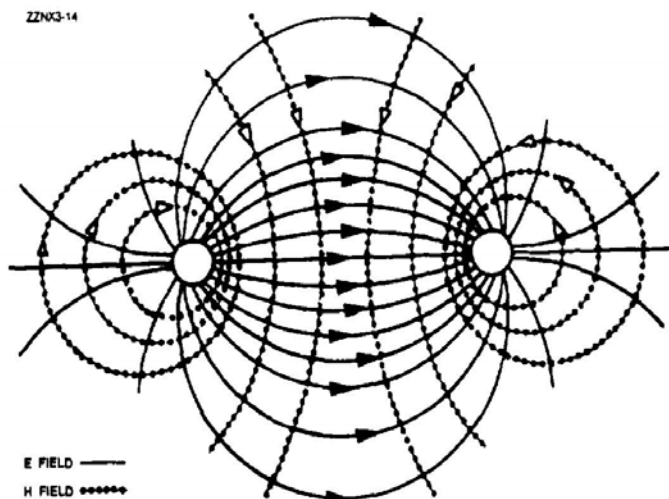

Figure 3-5.—Leakage in a transmission line.

## ELECTROMAGNETIC FIELDS

The distributed constants of resistance, inductance, and capacitance are basic properties common to all transmission lines and exist whether or not any current flow exists. As soon as current flow and voltage exist in a transmission line, another property becomes quite evident. This is the presence of an electromagnetic field, or lines of force, about the wires of the transmission line. The lines of force themselves are not visible; however, understanding the force that an electron experiences while in the field of these lines is very important to your understanding of energy transmission.

There are two kinds of fields; one is associated with voltage and the other with current. The field associated with voltage is called the **ELECTRIC (E) FIELD**. It exerts a force on any electric charge placed in it. The field associated with current is called a **MAGNETIC (H) FIELD**, because it tends to exert a force on any magnetic pole placed in it. Figure 3-6 illustrates the way in which the E fields and H fields tend to orient themselves between conductors of a typical two-wire transmission line. The illustration shows a cross section of the transmission lines. The E field is represented by solid lines and the H field by dotted lines. The arrows indicate the direction of the lines of force. Both fields normally exist together and are spoken of collectively as the electromagnetic field.



## CHARACTERISTIC IMPEDANCE

You can describe a transmission line in terms of its impedance. The ratio of voltage to current ( $E_{in}/I_{in}$ ) at the input end is known as the **INPUT IMPEDANCE ( $Z_{in}$ )**. This is the impedance presented to the transmitter by the transmission line and its load, the antenna. The ratio of voltage to current at the output ( $E_{out}/I_{out}$ ) end is known as the **OUTPUT IMPEDANCE ( $Z_{out}$ )**. This is the impedance presented to the load by the transmission line and its source. If an infinitely long transmission line could be used, the ratio of voltage to current at any point on that transmission line would be some particular value of impedance. This impedance is known as the **CHARACTERISTIC IMPEDANCE**.

The maximum (and most efficient) transfer of electrical energy takes place when the source impedance is matched to the load impedance. This fact is very important in the study of transmission lines and antennas. If the characteristic impedance of the transmission line and the load impedance are equal, energy from the transmitter will travel down the transmission line to the antenna with no power loss caused by reflection.

## LINE LOSSES

The discussion of transmission lines so far has not directly addressed **LINE LOSSES**; actually some losses occur in all lines. Line losses may be any of three types—**COPPER**, **DIELECTRIC**, and **RADIATION** or **INDUCTION LOSSES**.

**NOTE:** Transmission lines are sometimes referred to as rf lines. In this text the terms are used interchangeably.

### Copper Losses

One type of copper loss is **I<sup>2</sup>R LOSS**. In rf lines the resistance of the conductors is never equal to zero. Whenever current flows through one of these conductors, some energy is dissipated in the form of heat. This heat loss is a **POWER LOSS**. With copper braid, which has a resistance higher than solid tubing, this power loss is higher.

Another type of copper loss is due to SKIN EFFECT. When dc flows through a conductor, the movement of electrons through the conductor's cross section is uniform. The situation is somewhat different when ac is applied. The expanding and collapsing fields about each electron encircle other electrons. This phenomenon, called SELF INDUCTION, retards the movement of the encircled electrons. The flux density at the center is so great that electron movement at this point is reduced. As frequency is increased, the opposition to the flow of current in the center of the wire increases. Current in the center of the wire becomes smaller and most of the electron flow is on the wire surface. When the frequency applied is 100 megahertz or higher, the electron movement in the center is so small that the center of the wire could be removed without any noticeable effect on current. You should be able to see that the effective cross-sectional area decreases as the frequency increases. Since resistance is inversely proportional to the cross-sectional area, the resistance will increase as the frequency is increased. Also, since power loss increases as resistance increases, power losses increase with an increase in frequency because of skin effect.

Copper losses can be minimized and conductivity increased in an rf line by plating the line with silver. Since silver is a better conductor than copper, most of the current will flow through the silver layer. The tubing then serves primarily as a mechanical support.

### **Dielectric Losses**

DIELECTRIC LOSSES result from the heating effect on the dielectric material between the conductors. Power from the source is used in heating the dielectric. The heat produced is dissipated into the surrounding medium. When there is no potential difference between two conductors, the atoms in the dielectric material between them are normal and the orbits of the electrons are circular. When there is a potential difference between two conductors, the orbits of the electrons change. The excessive negative charge on one conductor repels electrons on the dielectric toward the positive conductor and thus distorts the orbits of the electrons. A change in the path of electrons requires more energy, introducing a power loss.

The atomic structure of rubber is more difficult to distort than the structure of some other dielectric materials. The atoms of materials, such as polyethylene, distort easily. Therefore, polyethylene is often used as a dielectric because less power is consumed when its electron orbits are distorted.

### **Radiation and Induction Losses**

RADIATION and INDUCTION LOSSES are similar in that both are caused by the fields surrounding the conductors. Induction losses occur when the electromagnetic field about a conductor cuts through any nearby metallic object and a current is induced in that object. As a result, power is dissipated in the object and is lost.

Radiation losses occur because some magnetic lines of force about a conductor do not return to the conductor when the cycle alternates. These lines of force are projected into space as radiation, and this results in power losses. That is, power is supplied by the source, but is not available to the load.

### **VOLTAGE CHANGE**

In an electric circuit, energy is stored in electric and magnetic fields. These fields must be brought to the load to transmit that energy. At the load, energy contained in the fields is converted to the desired form of energy.

### **Transmission of Energy**

When the load is connected directly to the source of energy, or when the transmission line is short, problems concerning current and voltage can be solved by applying Ohm's law. When the transmission line becomes long enough so the time difference between a change occurring at the generator and a change appearing at the load becomes appreciable, analysis of the transmission line becomes important.

### **Dc Applied to a Transmission Line**

In figure 3-7, a battery is connected through a relatively long two-wire transmission line to a load at the far end of the line. At the instant the switch

is closed, neither current nor voltage exists on the line. When the switch is closed, point A becomes a positive potential, and point B becomes negative. These points of difference in potential move down the line. However, as the initial points of potential leave points A and B, they are followed by new points of difference in potential, which the battery adds at A and B. This is merely saying that the battery maintains a constant potential difference between points A and B. A short time after the switch is closed, the initial points of difference in potential have reached points A' and B'; the wire sections from points A to A' and points B to B' are at the same potential as A and B, respectively. The points of charge are represented by plus

(+) and minus (-) signs along the wires. The directions of the currents in the wires are represented by the arrowheads on the line, and the direction of travel is indicated by an arrow below the line. Conventional lines of force represent the electric field that exists between the opposite kinds of charge on the wire sections from A to A' and B to B'. Crosses (tails of arrows) indicate the magnetic field created by the electric field moving down the line. The moving electric field and the accompanying magnetic field constitute an electromagnetic wave that is moving from the generator (battery) toward the load. This wave travels at approximately the speed of light in free space. The energy reaching the load is equal to that developed at the battery (assuming there are no losses in the transmission line). If the load absorbs all of the energy, the current and voltage will be evenly distributed along the line.

### Ac Applied to a Transmission Line

When the battery of figure 3-7 is replaced by an ac generator (fig. 3-8), each successive instantaneous value of the generator voltage is propagated down the

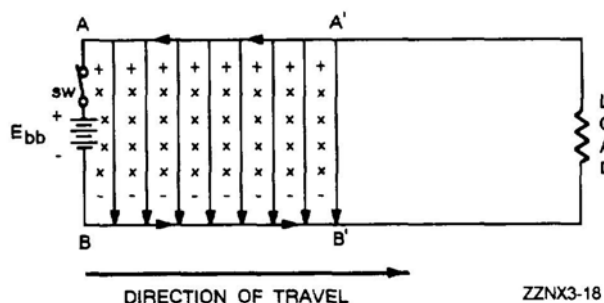

Figure 3-7.—Dc voltage applied to a line.

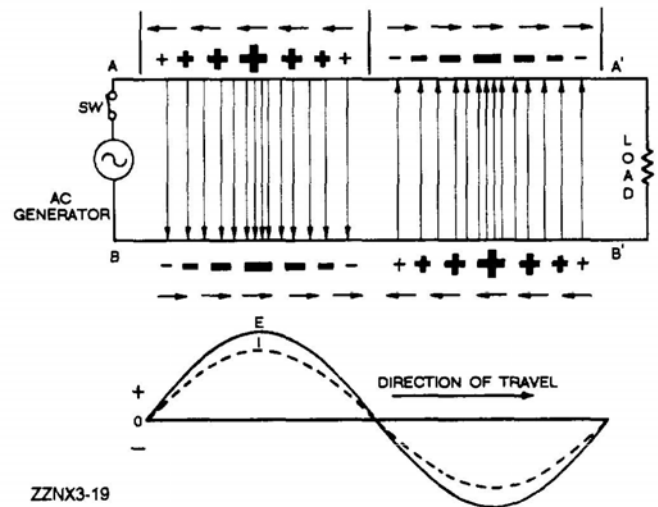

Figure 3-8.—Ac voltage applied to a line.

line at the speed of light. The action is similar to the wave created by the battery, except the applied voltage is sinusoidal instead of constant. Assume that the switch is closed at the moment the generator voltage is passing through zero and that the next half cycle makes point A positive. At the end of one cycle of generator voltage, the current and voltage distribution will be as shown in figure 3-8.

In this illustration the conventional lines of force represent the electric fields. For simplicity, the magnetic fields are not shown. Points of charge are indicated by plus (+) and minus (-) signs, the larger signs indicating points of higher amplitude of both voltage and current. Short arrows indicate direction of current (electron flow). The waveform drawn below the transmission line represents the voltage (E) and current (I) waves. The line is assumed to be infinite in length so there is no reflection. Thus, traveling sinusoidal voltage and current waves continually travel in phase from the generator toward the load, or far end of the line. Waves traveling from the generator to the load are called INCIDENT WAVES. Waves traveling from the load back to the generator are called REFLECTED WAVES and will be explained in later paragraphs.

### STANDING-WAVE RATIO

The measurement of standing waves on a transmission line yields information about equipment operating

conditions. Maximum power is absorbed by the load when  $Z_L = Z_0$ . If a line has no standing waves, the termination for that line is correct and maximum power transfer takes place.

You have probably noticed that the variation of standing waves shows how near the rf line is to being terminated in  $Z_0$ . A wide variation in voltage along the length means a termination far from  $Z_0$ . A small variation means termination near  $Z_0$ . Therefore, the ratio of the maximum to the minimum is a measure of the perfection of the termination of a line. This ratio is called the STANDING-WAVE RATIO (swr) and is always expressed in whole numbers. For example, a ratio of 1:1 describes a line terminated in its characteristic impedance ( $Z_0$ ).

### Voltage Standing-Wave Ratio

The ratio of maximum voltage to minimum voltage on a line is called the VOLTAGE STANDING-WAVE RATIO (vswr). Therefore:

$$\text{vswr} = \left| \frac{E_{\max}}{E_{\min}} \right|$$

The vertical lines in the formula indicate that the enclosed quantities are absolute and that the two values are taken without regard to polarity. Depending on the nature of the standing waves, the numerical value of vswr ranges from a value of 1 ( $Z_L = Z_0$ , no standing waves) to an infinite value for theoretically complete reflection. Since there is always a small loss on a line, the minimum voltage is never zero and the vswr is always some finite value. However, if the vswr is to be a useful quantity, the power losses along the line must be small in comparison to the transmitted power.

### Power Standing-Wave Ratio

The square of the vswr is called the POWER STANDING-WAVE RATIO (pswr). Therefore:

$$\text{pswr} = \frac{P_{\max}}{P_{\min}}$$

This ratio is useful because the instruments used to detect standing waves react to the square of the

voltage. Since power is proportional to the square of the voltage, the ratio of the square of the maximum and minimum voltages is called the power standing-wave ratio. In a sense, the name is misleading because the power along a transmission line does not vary.

### Current Standing-Wave Ratio

The ratio of maximum to minimum current along a transmission line is called CURRENT STANDING-WAVE RATIO (iswr). Therefore:

$$\text{iswr} = \left| \frac{I_{\max}}{I_{\min}} \right|$$

This ratio is the same as that for voltages. It can be used where measurements are made with loops that sample the magnetic field along a line. It gives the same results as vswr measurements.

## TRANSMISSION MEDIUMS

The Navy uses many different types of TRANSMISSION MEDIUMS in its electronic applications. Each medium (line or waveguide) has a certain characteristic impedance value, current-carrying capacity, and physical shape and is designed to meet a particular requirement.

The five types of transmission mediums that we will discuss in this topic include PARALLEL-LINE, TWISTED PAIR, SHIELDED PAIR, COAXIAL LINE, and WAVEGUIDES. The use of a particular line depends, among other things, on the applied frequency, the power-handling capabilities, and the type of installation.

### Parallel Line

One type of parallel line is the TWO-WIRE OPEN LINE, illustrated in figure 3-9. This line consists of two wires that are generally spaced from 2 to 6 inches apart by insulating spacers. This type of line is most often used for power lines, rural telephone lines, and telegraph lines. It is sometimes used as a transmission line between a transmitter and an antenna or between an antenna and a receiver. An advantage of this type



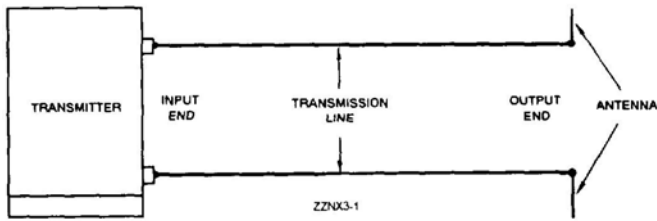

Figure 3-9.—Two-wire open line.

of line is its simple construction. The principal disadvantages of this type of line are the high radiation losses and electrical noise pickup because of the lack of shielding. Radiation losses are produced by the changing fields created by the changing current in each conductor.

Another type of parallel line is the TWO-WIRE RIBBON (TWIN LEAD) LINE, illustrated in figure 3-10. This type of transmission line is commonly used to connect a television receiving antenna to a home television set. This line is essentially the same as the two-wire open line except that uniform spacing is assured by embedding the two wires in a low-loss dielectric, usually polyethylene. Since the wires are embedded in the thin ribbon of polyethylene, the dielectric space is partly air and partly polyethylene.

### Twisted Pair

The TWISTED PAIR transmission line is illustrated in figure 3-11. As the name implies, the line consists of two insulated wires twisted together to form a flexible line without the use of spacers. It is not used for transmitting high frequency because of the high dielectric losses that occur in the rubber insulation. When the line is wet, the losses increase greatly.

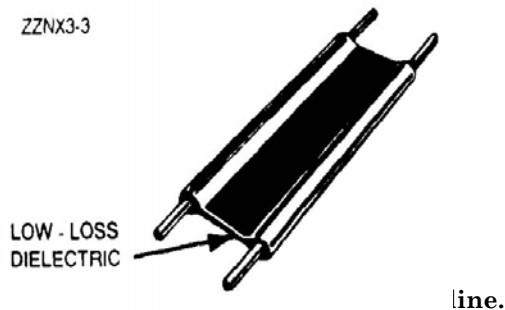

line.



Figure 3-11.—Twisted pair.

### Shielded Pair

The SHIELDED PAIR, shown in figure 3-12, consists of parallel conductors separated from each other and surrounded by a solid dielectric. The conductors are contained within a braided copper tubing that acts as an electrical shield. The assembly is covered with a rubber or flexible composition coating that protects the line from moisture and mechanical damage. Outwardly, it looks much like the power cord of a washing machine or refrigerator.

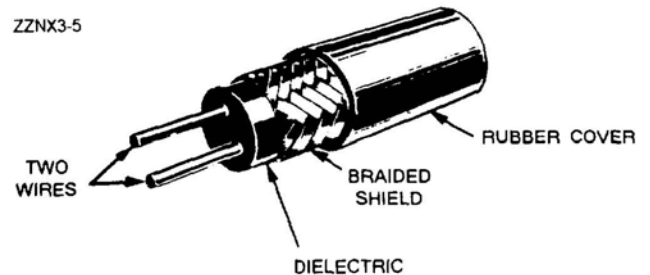

Figure 3-12.—Shielded pair.

The principal advantage of the shielded pair is that the conductors are balanced to ground; that is, the capacitance between the wires is uniform throughout the length of the line. This balance is due to the uniform spacing of the grounded shield that surrounds the wires along their entire length. The braided copper shield isolates the conductors from stray magnetic fields.

### Coaxial Lines

There are two types of COAXIAL LINES, RIGID (AIR) COAXIAL LINE and FLEXIBLE (SOLID) COAXIAL LINE. The physical construction of both types is basically the same; that is, each contains two concentric conductors.

The rigid coaxial line consists of a central, insulated wire (inner conductor) mounted inside a tubular outer conductor. This line is shown in figure 3-13. In some applications, the inner conductor is also tubular. The inner conductor is insulated from the outer conductor by insulating spacers or beads at regular intervals. The spacers are made of Pyrex, polystyrene, or some other material that has good insulating characteristics and low dielectric losses at high frequencies.

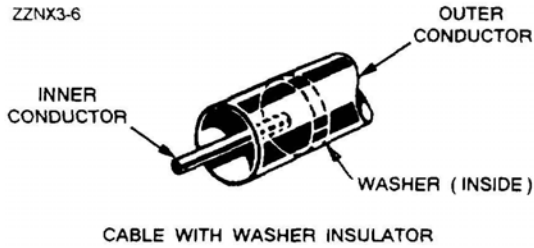

Figure 3-13.—Air coaxial line.

The chief advantage of the rigid line is its ability to minimize radiation losses. The electric and magnetic fields in a two-wire parallel line extend into space for relatively great distances and radiation losses occur. However, in a coaxial line no electric or magnetic fields extend outside of the outer conductor. The fields are confined to the space between the two conductors, resulting in a perfectly shielded coaxial line. Another advantage is that interference from other lines is reduced.

The rigid line has the following disadvantages:

(1) it is expensive to construct; (2) it must be kept dry to prevent excessive leakage between the two conductors; and (3) although high-frequency losses are somewhat less than in previously mentioned lines, they are still excessive enough to limit the practical length of the line.

Leakage caused by the condensation of moisture is prevented in some rigid line applications by the use of an inert gas, such as nitrogen, helium, or argon. It is pumped into the dielectric space of the line at a pressure that can vary from 3 to 35 pounds per square inch. The inert gas is used to dry the line when it is first installed and pressure is maintained to ensure that no moisture enters the line.

Flexible coaxial lines (fig. 3-14) are made with an inner conductor that consists of flexible wire insulated from the outer conductor by a solid, continuous insulating material. The outer conductor is made of metal braid, which gives the line flexibility. Early attempts at gaining flexibility involved using rubber insulators between the two conductors. However, the rubber insulators caused excessive losses at high frequencies.

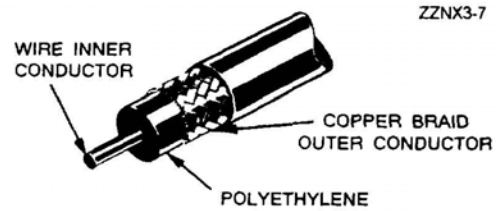

Figure 3-14.—Flexible coaxial line.

Because of the high-frequency losses associated with rubber insulators, polyethylene plastic was developed to replace rubber and eliminate these losses. Polyethylene plastic is a solid substance that remains flexible over a wide range of temperatures. It is unaffected by seawater, gasoline, oil, and most other liquids that may be found aboard ship. The use of polyethylene as an insulator results in greater high-frequency losses than the use of air as an insulator. However, these losses are still lower than the losses associated with most other solid dielectric materials.

This concludes our study of transmission lines. The rest of this chapter will be an introduction into the study of waveguides.

## WAVEGUIDE THEORY

The two-wire transmission line used in conventional circuits is inefficient for transferring electromagnetic energy at microwave frequencies. At these frequencies, energy escapes by radiation because the fields are not confined in all directions, as illustrated in figure 3-15. Coaxial lines are more efficient than two-wire lines for transferring electromagnetic energy because the fields are completely confined by the conductors, as illustrated in figure 3-16. Waveguides are the most

efficient way to transfer electromagnetic energy. WAVEGUIDES are essentially coaxial lines without center conductors. They are constructed from conductive material and may be rectangular, circular, or elliptical in shape, as shown in figure 3-17.

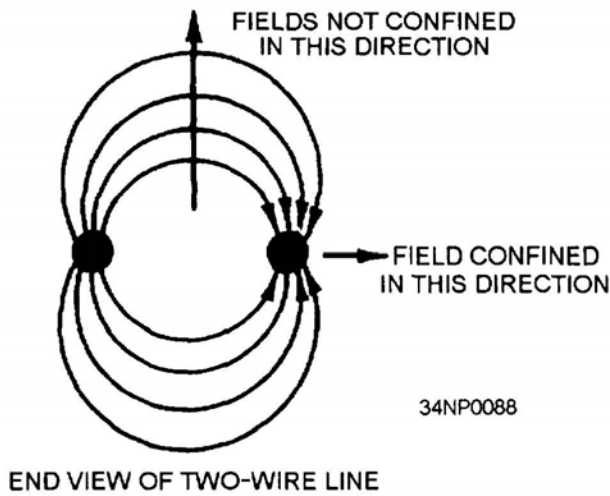

Figure 3-15.—Fields confined in two directions only.

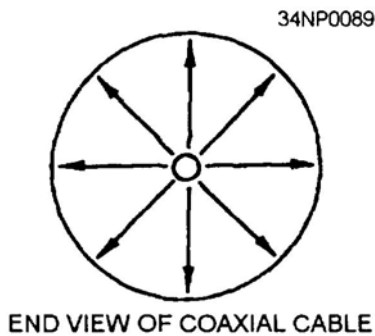

Figure 3-16.—Fields confined in all directions.

### WAVEGUIDE ADVANTAGES

Waveguides have several advantages over two-wire and coaxial transmission lines. For example, the large surface area of waveguides greatly reduces COPPER (I<sup>2</sup>R) LOSSES. Two-wire transmission lines have large copper losses because they have a relatively small surface area. The surface area of the outer conductor

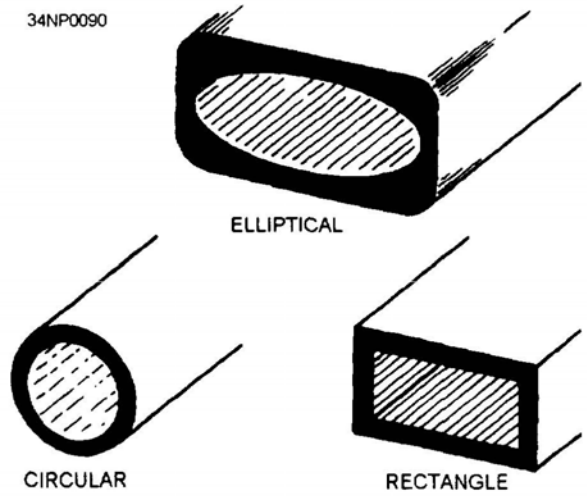

Figure 3-17.—Waveguide shapes.

of a coaxial cable is large, but the surface area of the inner conductor is relatively small. At microwave frequencies, the current-carrying area of the inner conductor is restricted to a very small layer at the surface of the conductor by an action called SKIN EFFECT.

Skin effect tends to increase the effective resistance of the conductor. Although energy transfer in coaxial cable is caused by electromagnetic field motion, the magnitude of the field is limited by the size of the current-carrying area of the inner conductor. The small size of the center conductor is even further reduced by skin effect, and energy transmission by coaxial cable becomes less efficient than by waveguides. DIELECTRIC LOSSES are also lower in waveguides than in two-wire and coaxial transmission lines. Dielectric losses in two-wire and coaxial lines are caused by the heating of the insulation between the conductors. The insulation behaves as the dielectric of a capacitor formed by the two wires of the transmission line. A voltage potential across the two wires causes heating of the dielectric and results in a power loss. In practical applications, the actual breakdown of the insulation between the conductors of a transmission line is more frequently a problem than is the dielectric loss.

This breakdown is usually caused by stationary voltage spikes or “nodes,” which are caused by standing waves. Standing waves are stationary and occur when part of the energy traveling down the line

is reflected by an impedance mismatch with the load. The voltage potential of the standing waves at the points of greatest magnitude can become large enough to break down the insulation between transmission line conductors.

The dielectric in waveguides is air, which has a much lower dielectric loss than conventional insulating materials. However, waveguides are also subject to dielectric breakdown caused by standing waves. Standing waves in waveguides cause arcing, which decreases the efficiency of energy transfer and can severely damage the waveguide. Also since the electromagnetic fields are completely contained within the waveguide, radiation losses are kept very low.

Power-handling capability is another advantage of waveguides. Waveguides can handle more power than coaxial lines of the same size because power-handling capability is directly related to the distance between conductors. Figure 3-18 illustrates the greater distance between conductors in a waveguide.

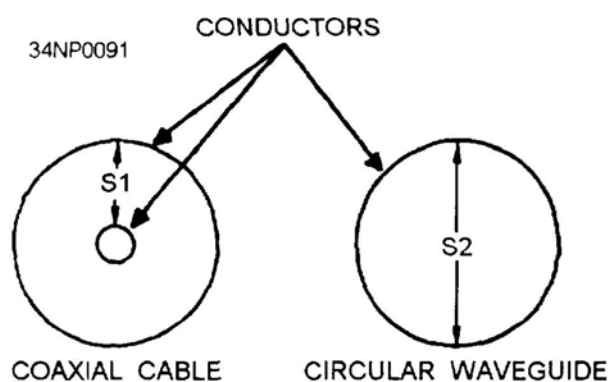

**Figure 3-18.—Comparison of spacing in coaxial cable and a circular waveguide.**

In view of the advantages of waveguides, you would think that waveguides should be the only type of transmission lines used. However, waveguides have certain disadvantages that make them practical for use only at microwave frequencies.

## WAVEGUIDE DISADVANTAGES

Physical size is the primary lower-frequency limitation of waveguides. The width of a waveguide must be approximately a half wavelength at the frequency of the wave to be transported. For example, a waveguide for use at 1 megahertz would be about 700 feet wide. This makes the use of waveguides at frequencies below 1000 megahertz increasingly impractical. The lower frequency range of any system using waveguides is limited by the physical dimensions of the waveguides.

Waveguides are difficult to install because of their rigid, hollow-pipe shape. Special couplings at the joints are required to assure proper operation. Also, the inside surfaces of waveguides are often plated with silver or gold to reduce skin effect losses. These requirements increase the costs and decrease the practicality of waveguide systems at any other than microwave frequencies.

## DEVELOPING THE WAVEGUIDE FROM PARALLEL LINES

You may better understand the transition from ordinary transmission line concepts to waveguide theories by considering the development of a waveguide from a two-wire transmission line. Figure 3-19 shows a section of a two-wire transmission line supported on two insulators. At the junction with the line, the insulators must present a very high impedance to ground for proper operation of the line. A low impedance insulator would obviously short-circuit the line to ground, and this is what happens at very high frequencies. Ordinary insulators display the characteristics of the dielectric of a capacitor formed by the wire and ground. As the frequency increases, the overall impedance decreases. A better high-frequency insulator is a quarter-wave section of transmission line shorted at one end. Such an insulator is shown in figure 3-20. The impedance of a shorted quarter-wave section is very high at the open-end junction with the two-wire transmission line. This type of insulator is known as a METALLIC INSULATOR and may be placed anywhere along a two-wire line.

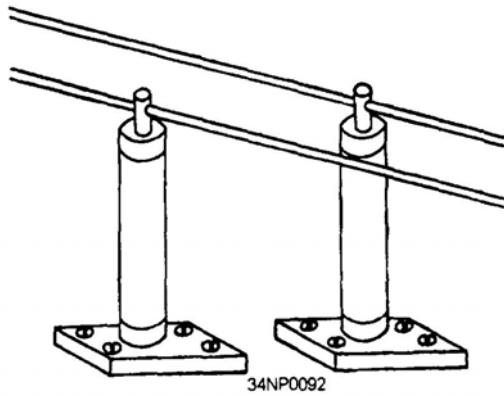

Figure 3-19.—Two-wire transmission line.

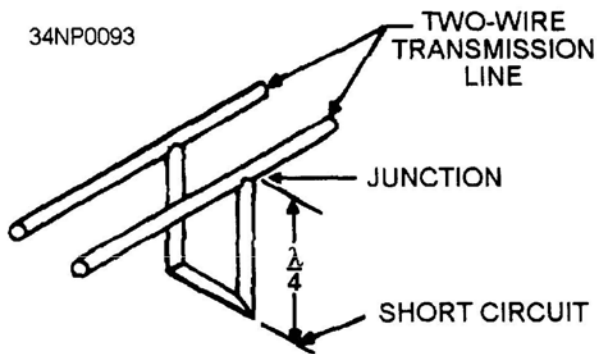

Figure 3-20.—Quarter-wave section of transmission line shorted at one end.

Note that quarter-wave sections are insulators at only one frequency. This severely limits the bandwidth, efficiency, and application of this type of two-wire line.

Figure 3-21 shows several metallic insulators on each side of a two-wire transmission line. As more insulators are added, each section makes contact with the next, and a rectangular waveguide is formed. The lines become part of the walls of the waveguide, as illustrated in figure 3-22. The energy is then conducted within the hollow waveguide instead of along the two-wire transmission line.

The comparison of the way electromagnetic fields work on a transmission line and in a waveguide is not exact. During the change from a two-wire line to a waveguide, the electromagnetic field configurations also undergo many changes. As a result of these changes, the waveguide does not actually operate

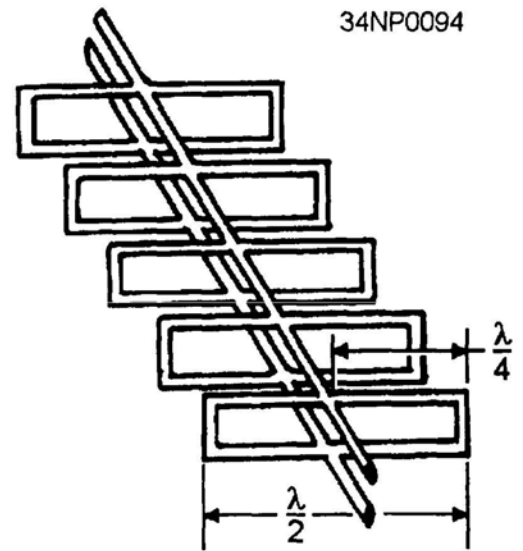

Figure 3-21.—Metallic insulator on each side of a two-wire line.

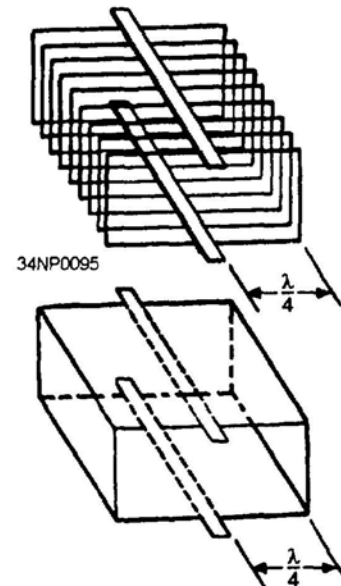

Figure 3-22.—Forming a waveguide by adding quarter-wave sections.

like a two-wire line that is completely shunted by quarter-wave sections. If it did, the use of a waveguide would be limited to a single-frequency wave length that was four times the length of the quarter-wave sections. In fact, waves of this length cannot pass efficiently through waveguides. Only a small range of frequencies of somewhat shorter wavelength (higher frequency) can pass efficiently.

As shown in figure 3-23, the widest dimension of a waveguide is called the “a” dimension and determines the range of operating frequencies. The narrowest dimension determines the power-handling capability of the waveguide and is called the “b” dimension.

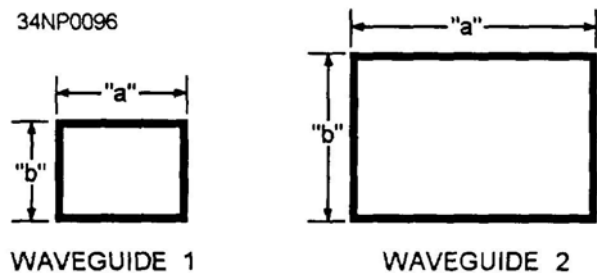

Figure 3-23.—Labeling waveguide dimensions,

**NOTE:** This method of labeling waveguides is not standard in all texts. Different methods may be used in other texts on microwave principles, but this method is in accordance with Navy Military Standards (MIL-STDS).

In theory, a waveguide could function at an infinite number of frequencies higher than the designed frequency; however, in practice, an upper frequency limit is caused by modes of operation, which will be discussed later.

If the frequency of a signal is decreased so much that two quarter-wavelengths are longer than the wide dimension of a waveguide, energy will no longer pass through the waveguide. This is the lower frequency limit, or CUTOFF FREQUENCY of a given waveguide. In practical applications, the wide dimension of a waveguide is usually 0.7 wavelength at the operating frequency. This allows the waveguide to handle a small range of frequencies both above and below the operating frequency. The “b” dimension is governed by the breakdown potential of the dielectric, which is usually air. Dimensions ranging from 0.2 to 0.5 wavelength are common for the “b” sides of a waveguide.

## ENERGY PROPAGATION IN WAVEGUIDES

Since energy is transferred through waveguides by electromagnetic fields, you need a basic understanding of field theory. Both electric (E FIELD) and magnetic fields (H FIELD) are present in waveguides, and the interaction of these fields causes energy to travel through the waveguide. This action is best understood by first looking at the properties of the two individual fields.

### E Field

An electric field exists when a difference of potential causes a stress in the dielectric between two points. The simplest electric field is one that forms between the plates of a capacitor when one plate is made positive compared to the other, as shown in view A of figure 3-24. The stress created in the dielectric is an electric field.

Electric fields are represented by arrows that point from the positive toward the negative potential. The number of arrows shows the relative strength of the field. In view B, for example, evenly spaced arrows indicate the field is evenly distributed. For ease of explanation, the electric field is abbreviated E field, and the lines of stress are called E lines.

### H Field

The magnetic field in a waveguide is made up of magnetic lines of force that are caused by current flow through the conductive material of the waveguide. Magnetic lines of force, called H lines, are continuous closed loops, as shown in figure 3-25. All of the H lines associated with current are collectively called a magnetic field or H field. The strength of the H field, indicated by the number of H lines in a given area, varies directly with the amount of current.

Although H lines encircle a single, straight wire, they behave differently when the wire is formed into a coil, as shown in figure 3-26. In a coil the individual H lines tend to form around each turn of wire. Since

34NP0097

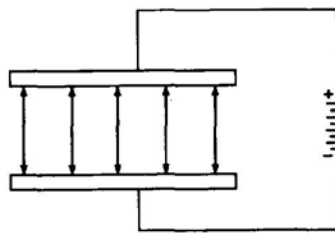

(A) CAPACITOR

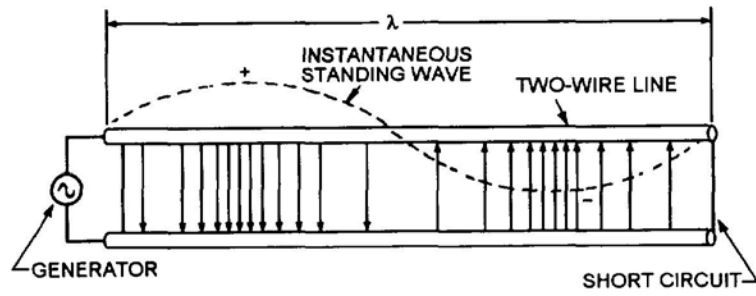

(B) TWO-WIRE TRANSMISSION LINE

Figure 3-24.—Simple electric fields.

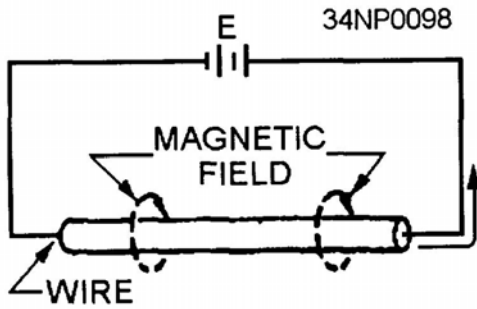

Figure 3-25.—Magnetic field on a single wire.

the H lines take opposite directions between adjacent turns, the field between the turns is canceled. Inside and outside the coil, where the direction of each H field is the same, the fields join and form continuous H lines around the entire coil. A similar action takes place in a waveguide.

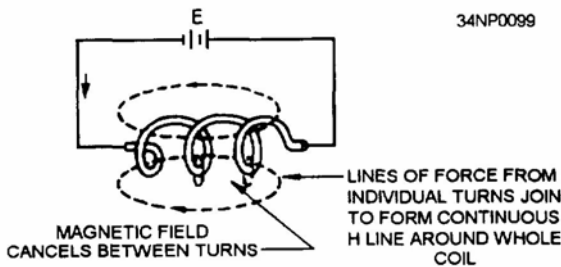

Figure 3-26.—Magnetic field on a coil.

### BOUNDARY CONDITIONS IN A WAVEGUIDE

The travel of energy down a waveguide is similar, but not identical, to the travel of electromagnetic waves in free space. The difference is that the energy in a

waveguide is confined to the physical limits of the guide. Two conditions, known as BOUNDARY CONDITIONS, must be satisfied for energy to travel through a waveguide.

The first boundary condition (illustrated in fig. 3-27, view A) can be stated as follows:

**For an electric field to exist at the surface of a conductor, it must be perpendicular to the conductor.**

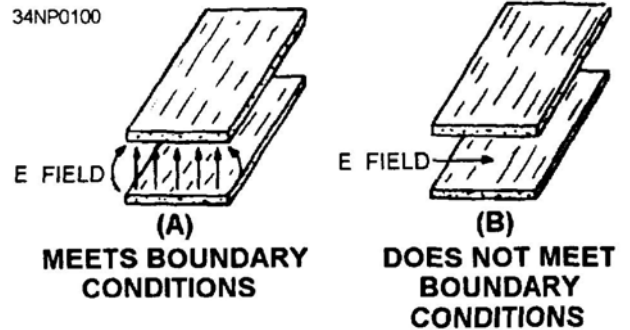

Figure 3-27.—E field boundary condition.

The opposite of this boundary condition, shown in view B, is also true. An electric field CANNOT exist parallel to a perfect conductor.

The second boundary condition, which is illustrated in figure 3-28, can be stated as follows:

**For a varying magnetic field to exist, it must form closed loops in parallel with the conductors and be perpendicular to the electric field.**

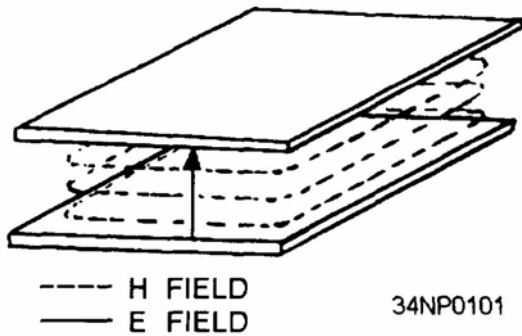

Figure 3-28.—H field boundary condition.

Since an E field causes a current flow that in turn produces an H field, both fields always exist at the same time in a waveguide. If a system satisfies one of these boundary conditions, it must also satisfy the other since neither field can exist alone.

### WAVEFRONTS WITHIN A WAVEGUIDE

Electromagnetic energy transmitted into space consists of electric and magnetic fields that are at right angles (90 degrees) to each other and at right angles to the direction of propagation. A simple analogy to establish this relationship is by use of the right-hand rule for electromagnetic energy, based on the POYNTING VECTOR. It indicates that a screw (right-hand thread) with its axis perpendicular to the electric and magnetic fields will advance in the direction of propagation if the E field is rotated to the right (toward the H field). This rule is illustrated in figure 3-29.

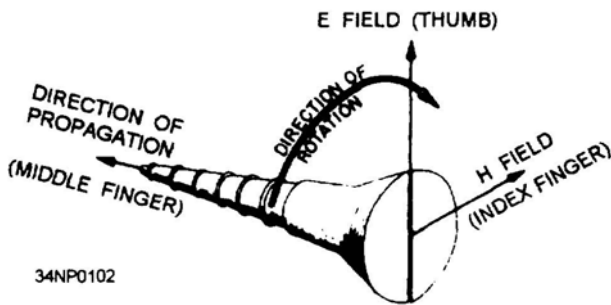

Figure 3-29.—The Poynting vector.

The combined electric and magnetic fields form a wavefront that can be represented by alternate negative and positive peaks at half-wavelength

as illustrated in figure 3-30. Angle  $\theta$  is the angle of travel of the wave with respect to some reference axis.

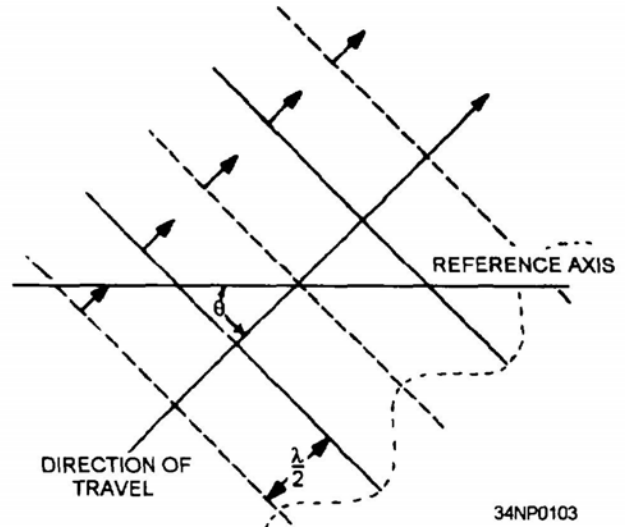

Figure 3-30.—Wavefronts in space.

The reflection of a single wavefront off the "b" wall of a waveguide is shown in figure 3-31. The wavefront is shown in view A as small particles. In views B and C particle 1 strikes the wall and is bounced back from the wall without losing velocity. If the wall is perfectly flat, the angle at which it strikes the wall, known as the angle of incidence ( $\theta$ ), is the same as the angle of reflection ( $\theta$ ). An instant after particle 1 strikes the wall, particle 2 strikes the wall, as shown



in view C, and reflects in the same manner. Because all the particles are traveling at the same velocity, particles 1 and 2 do not change their relative position with respect to each other. Therefore, the reflected wave has the same shape as the original. The remaining particles as shown in views D, E, and F reflect in the same manner. This process results in a reflected wavefront identical in shape, but opposite in polarity, to the incident wave.

**Figure 3-31.—Reflection of a single wavefront.**

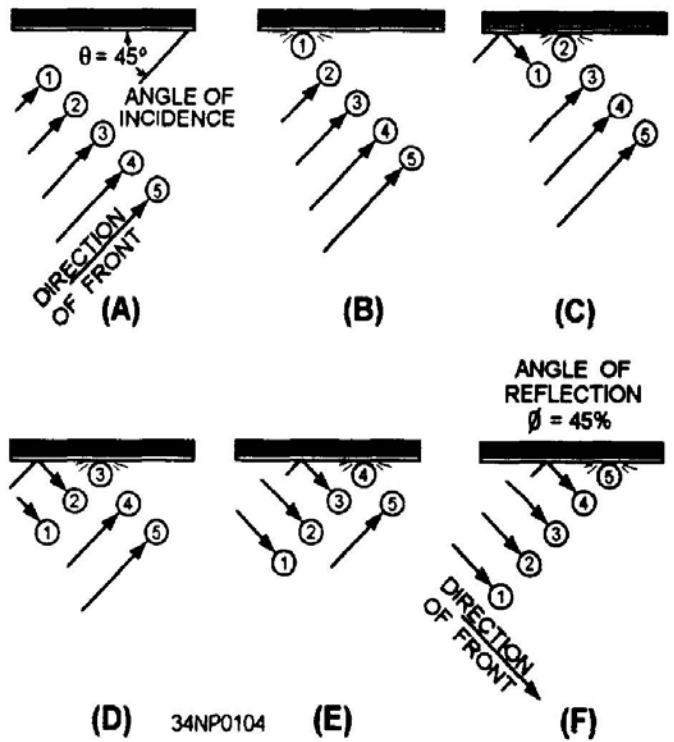

Figure 3-32, views A and B, each illustrate the direction of propagation of two different electromagnetic wavefronts of different frequencies being radiated into a waveguide by a probe. Note that only the direction of propagation is indicated by the lines and arrowheads. The wavefronts are at right angles to the direction of propagation. The angle of incidence ( $\theta$ ) and the angle of reflection ( $\phi$ ) of the

wavefronts vary in size with the frequency of the input energy, but the angles of reflection are equal to each other in a waveguide. The CUTOFF FREQUENCY

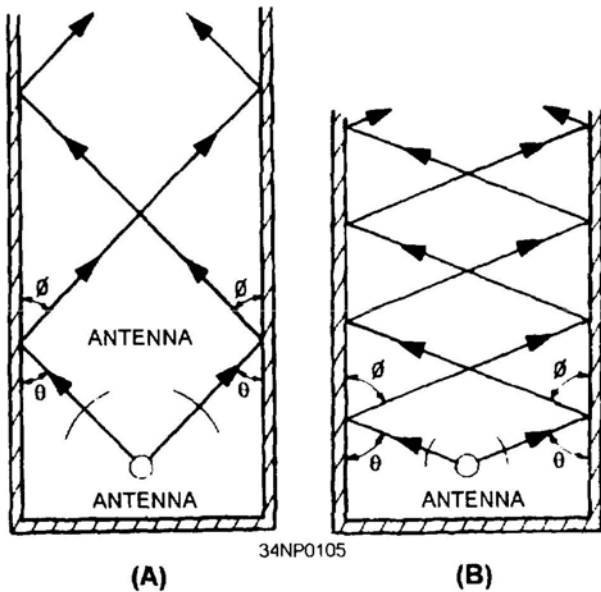

Figure 3-32.—Different frequencies in a waveguide.

across the guide (setting up standing waves) and no energy will be conducted down the waveguide.

The velocity of propagation of a wave along a waveguide is less than its velocity through free space (speed of light). This lower velocity is caused by the zigzag path taken by the wavefront. The forward-progress velocity of the wavefront in a waveguide is called GROUP VELOCITY and is somewhat slower than the speed of light.

The group velocity of energy in a waveguide is determined by the reflection angle of the wavefronts off the "b" walls. The reflection angle is determined by the frequency of the input energy. This basic principle is illustrated in figure 3-33. As frequency is decreased, the reflection angle increases, causing the group velocity to decrease. The opposite is also true; increasing frequency increases the group velocity.

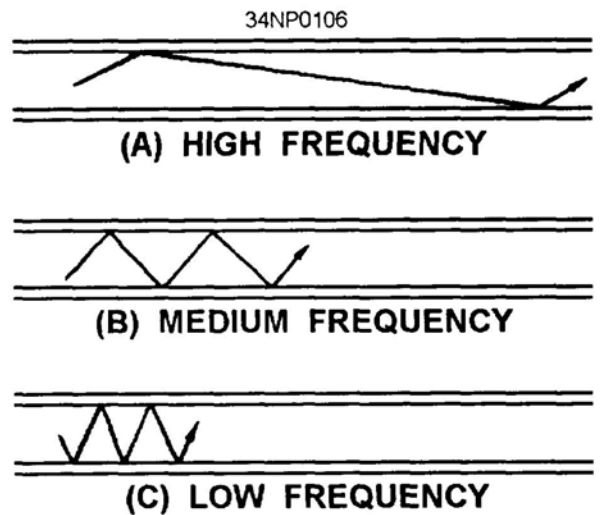

Figure 3-33.—Reflection angle at various frequencies.

### WAVEGUIDE MODES OF OPERATION

The waveguide analyzed in the previous paragraphs yields an electric field configuration known as the half-sine electric distribution. This configuration, called a MODE OF OPERATION, is shown in figure 3-34. Recall that the strength of the field is indicated by the spacing of the lines; that is, the closer the lines, the stronger the field. The regions of maximum voltage in this field move continuously down the waveguide in a sine-wave pattern. To meet boundary conditions, the field must always be zero at the "b" walls.

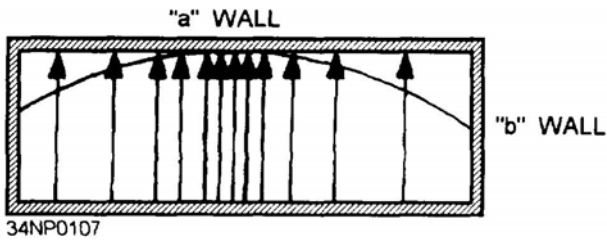

Figure 3-34.—Half-sine E field distribution.

The half-sine field is only one of many field configurations, or modes, that can exist in a rectangular waveguide. A full-sine field can also exist in a rectangular waveguide because, as shown in figure 3-35, the field is zero at the “b” walls.

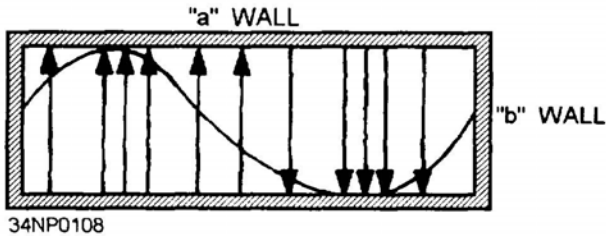

Figure 3-35.—Full-sine E field distribution.

The magnetic field in a rectangular waveguide is in the form of closed loops parallel to the surface of the conductors. The strength of the magnetic field is proportional to the electric field. Figure 3-36 illustrates the magnetic field pattern associated with a half-sine electric field distribution. The magnitude of the magnetic field varies in a sine-wave pattern down the center of the waveguide in “time phase” with the electric field. TIME PHASE means that the peak H lines and peak E lines occur at the same instant in time, although not necessarily at the same point along the length of the waveguide.

The dominant mode is the most efficient mode. Waveguides are normally designed so that only the dominant mode will be used. To operate in the dominant mode, a waveguide must have an “a” (wide) dimension of at least one half-wavelength of the frequency to be propagated. The “a” dimension of the waveguide must be kept near the minimum allowable value to ensure that only the dominant mode will exist. In practice, this dimension is usually 0.7 wavelength.

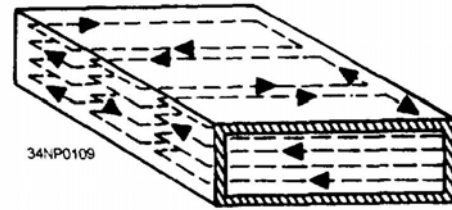

Figure 3-36.—Magnetic field caused by a half-sine E field.

Of the possible modes of operation available for a given waveguide, the dominant mode has the lowest cutoff frequency. The high-frequency limit of a rectangular waveguide is a frequency at which its “a” dimension becomes large enough to allow operation in a mode higher than that for which the waveguide has been designed.

Circular waveguides are used in specific areas of radar and communications systems, such as rotating joints used at the mechanical point where the antennas rotate. Figure 3-37 illustrates the dominant mode of a circular waveguide. The cutoff wavelength of a circular guide is 1.71 times the diameter of the waveguide. Since the “a” dimension of a rectangular waveguide is approximately one half-wavelength at the cutoff frequency, the diameter of an equivalent circular waveguide must be  $2/1.71$ , or approximately

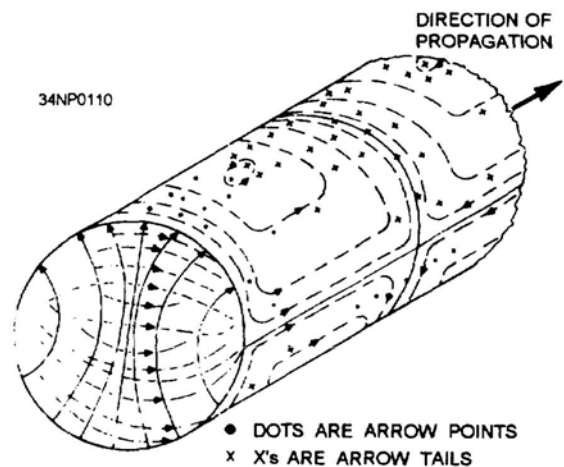

Figure 3-37.—Dominant mode in a circular waveguide.

1.17 times the “a” dimension of a rectangular waveguide.

### MODE NUMBERING SYSTEMS

So far, only the most basic types of E and H field arrangements have been shown. More complicated arrangements are often necessary to make possible coupling, isolation, or other types of operation. The field arrangements of the various modes of operation are divided into two categories: TRANSVERSE ELECTRIC (TE) and TRANSVERSE MAGNETIC (TM).

**In the transverse electric (TE) mode, the entire electric field is in the transverse plane, which is perpendicular to the waveguide, (direction of energy travel). Part of the magnetic field is parallel to the length axis.**

**In the transverse magnetic (TM) mode, the entire magnetic field is in the transverse plane and has no portion parallel to the length axis.**

Since there are several TE and TM modes, subscripts are used to complete the description of the field pattern. In rectangular waveguides, the first subscript indicates the number of half-wave patterns in the “a” dimension, and the second subscript indicates the number of half-wave patterns in the “b” dimension.

The dominant mode for rectangular waveguides is shown in figure 3-38. It is designated as the TE mode because the E fields are perpendicular to the “a” walls. The first subscript is 1, since there is only one half-wave pattern across the “a” dimension. There

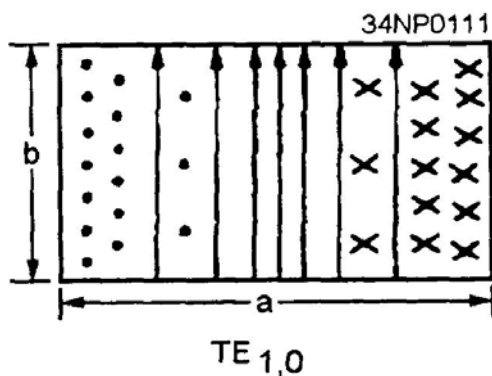

Figure 3-38.—TE<sub>1,0</sub> mode in a rectangular waveguide.

are no E-field patterns across the “b” dimension, so the second subscript is 0. The complete mode description of the dominant mode in rectangular waveguides is TE<sub>1,0</sub>. Subsequent description of waveguide operation in this text will assume the dominant (TE<sub>1,0</sub>) mode unless otherwise noted.

A similar system is used to identify the modes of circular waveguides. The general classification of TE and TM is true for both circular and rectangular waveguides. In circular waveguides the subscripts have a different meaning. The first subscript indicates the number of full-wave patterns around the circumference of the waveguide. The second subscript indicates the number of half-wave patterns across the diameter.

In the circular waveguide in figure 3-39, the E field is perpendicular to the length of the waveguide with no E lines parallel to the direction of propagation. Thus, it must be classified as operating in the TE mode. If you follow the E line pattern in a counterclockwise direction starting at the top, the E lines go from zero, through maximum positive (tail of arrows), back to zero, through maximum negative (head of arrows), and then back to zero again. This is one full wave, so the first subscript is 1. Along the diameter, the E lines go from zero through maximum and back to zero, making a half-wave variation. The second subscript, therefore, is also 1. TE<sub>1,1</sub> is the complete mode description of the dominant mode in circular waveguides. Several modes are possible in both circular and rectangular waveguides. Figure 3-40 illustrates several different modes that can be used to verify the mode numbering system.

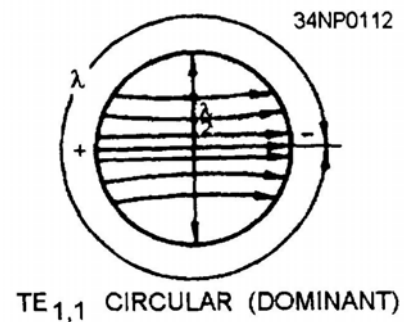

Figure 3-39.—Counting wavelengths in a circular waveguide.

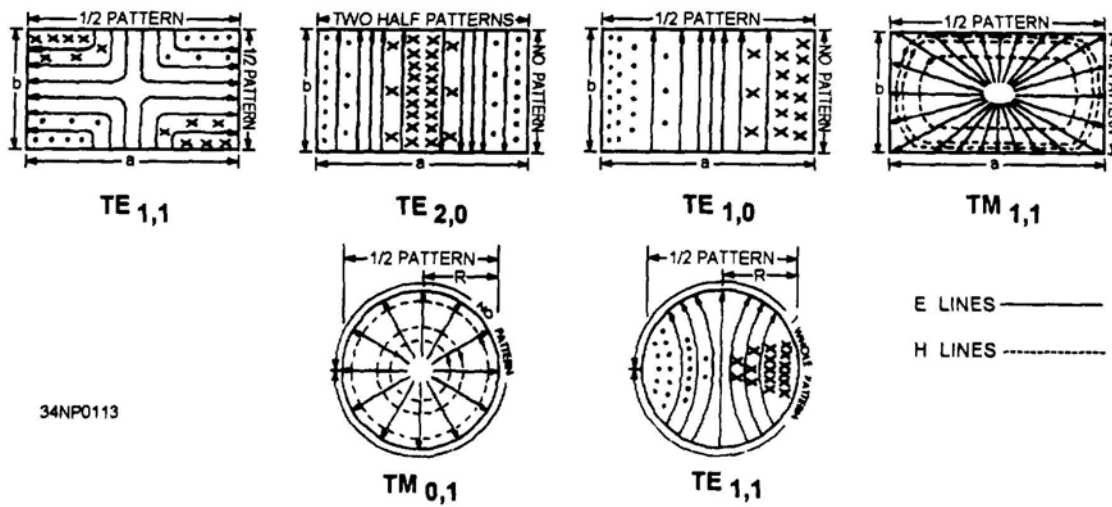

Figure 3-40.—Various modes of operation for rectangular and circular waveguides.

### WAVEGUIDE INPUT/OUTPUT METHODS

A waveguide, as explained earlier in this topic, operates differently from an ordinary transmission line. Therefore, special devices must be used to put energy into a waveguide at one end and remove it from the other end.

The three devices used to inject or remove energy from waveguides are PROBES, LOOPS, and SLOTS. Slots may also be called APERTURES or WINDOWS.

When a small probe is inserted into a waveguide and supplied with microwave energy, it acts as a quarter-wave antenna. Current flows in the probe and sets up an E field such as the one shown in figure 3-41, view A. The E lines detach themselves from the probe. When the probe is located at the point of highest efficiency, the E lines set up an E field of considerable intensity.

The most efficient place to locate the probe is in the center of the “a” wall, parallel to the “b” wall, and one quarter-wavelength from the shorted end of the waveguide, as shown in figure 3-41, views B and C. This is the point at which the E field is maximum in the dominant mode. Therefore, energy transfer (coupling) is maximum at this point. Note that the quarter-wavelength spacing is at the frequency required to propagate the dominant mode.

In many applications a lesser degree of energy transfer, called loose coupling, is desirable. The amount of energy transfer can be reduced by decreasing the length of the probe, by moving it out of the center of the E field, or by shielding it. Where the degree of coupling must be varied frequently, the probe is made retractable so the length can be easily changed.

The size and shape of the probe determines its frequency, bandwidth, and power-handling capability. As the diameter of a probe increases, the bandwidth increases. A probe similar in shape to a door knob is capable of handling much higher power and a larger bandwidth than a conventional probe. The greater power-handling capability is directly related to the increased surface area. Two examples of broad-bandwidth probes are illustrated in figure 3-41, view D. Removal of energy from a waveguide is simply a reversal of the injection process using the same type of probe.

Another way of injecting energy into a waveguide is by setting up an H field in the waveguide. This can be accomplished by inserting a small loop that carries a high current into the waveguide, as shown in figure 3-42, view A. A magnetic field builds up around the loop and expands to fit the waveguide, as shown in view B. If the frequency of the current in the loop is within the bandwidth of the waveguide, energy will be transferred to the waveguide.

34NP0114

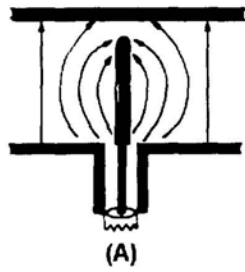

(A)

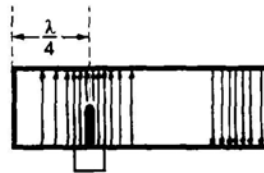

(B)

RECTANGULAR WAVEGUIDE

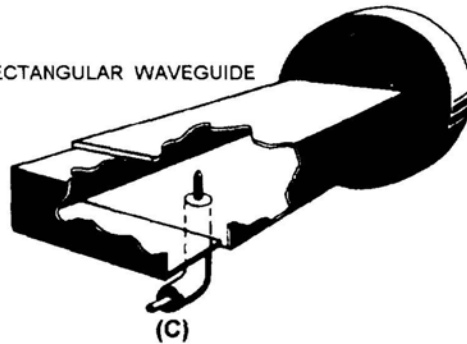

(C)

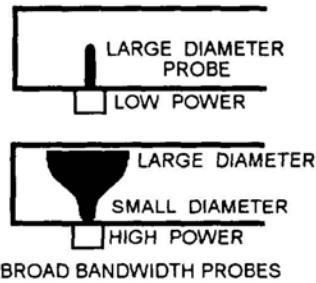

(D)

Figure 3-41.—Probe coupling in a rectangular waveguide.

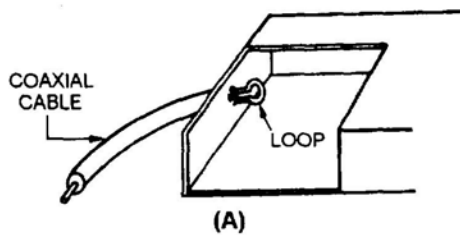

(A)

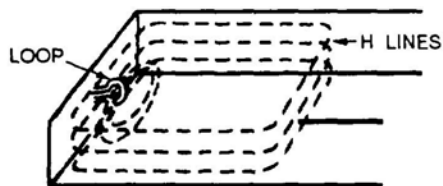

(B)

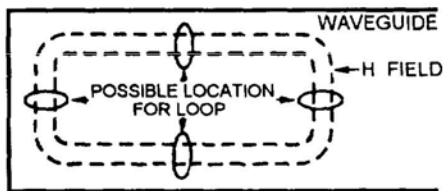

(C)

34NP0115

Figure 3-42.—Loop coupling in a rectangular waveguide.

For the most efficient coupling to the waveguide, the loop is inserted at one of several points where the magnetic field will be of greatest strength. Four of those points are shown in figure 3-42, view C.

When less efficient coupling is desired, you can rotate or move the loop until it encircles a smaller number of H lines. When the diameter of the loop is increased, its power-handling capability also increases. The bandwidth can be increased by increasing the size of the wire used to make the loop.

When a loop is introduced into a waveguide in which an H field is present, a current is induced in the loop. When this condition exists, energy is removed from the waveguide.

Slots or apertures are sometimes used when very loose (inefficient) coupling is desired, as shown in figure 3-43. In this method energy enters through a small slot in the waveguide and the E field expands into the waveguide. The E lines expand first across the slot and then across the interior of the waveguide.

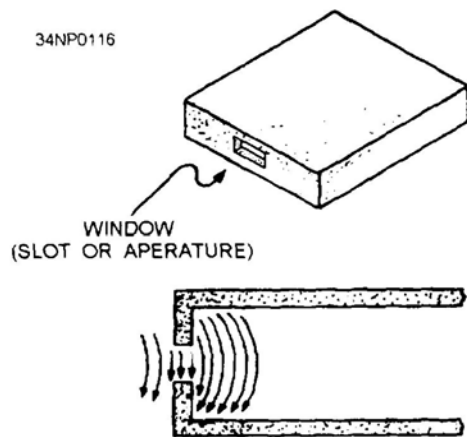

Figure 3-43.—Slot coupling in a waveguide.

Minimum reflections occur when energy is injected or removed if the size of the slot is properly proportioned to the frequency of the energy.

After learning how energy is coupled into and out of a waveguide with slots, you might think that leaving the end open is the most simple way of injecting or removing energy in a waveguide. This is not the case, however, because when energy leaves a waveguide, fields form around the end of the waveguide. These fields cause an impedance mismatch which, in turn, causes the development of standing waves and a drastic loss in efficiency. Various methods of impedance matching and terminating waveguides will be covered in the next section.

## WAVEGUIDE IMPEDANCE MATCHING

Waveguide transmission systems are not always perfectly impedance matched to their load devices. The standing waves that result from a mismatch cause a power loss, a reduction in power-handling capability, and an increase in frequency sensitivity. Impedance-changing devices are therefore placed in the waveguide to match the waveguide to the load. These devices are placed near the source of the standing waves.

Figure 3-44 illustrates three devices, called irises, that are used to introduce inductance or capacitance into a waveguide. An iris is nothing more than a metal plate that contains an opening through which the waves may pass. The iris is located in the transverse plane of either the magnetic or electric field.

An inductive iris and its equivalent circuit are illustrated in figure 3-44, view A. The iris places a shunt inductive reactance across the waveguide that is directly proportional to the size of the opening. Notice that the inductive iris is in the magnetic plane. The shunt capacitive reactance, illustrated in view B, basically acts the same way. Again, the reactance is directly proportional to the size of the opening, but the iris is placed in the electric plane. The iris, illustrated in view C, has portions in both the magnetic

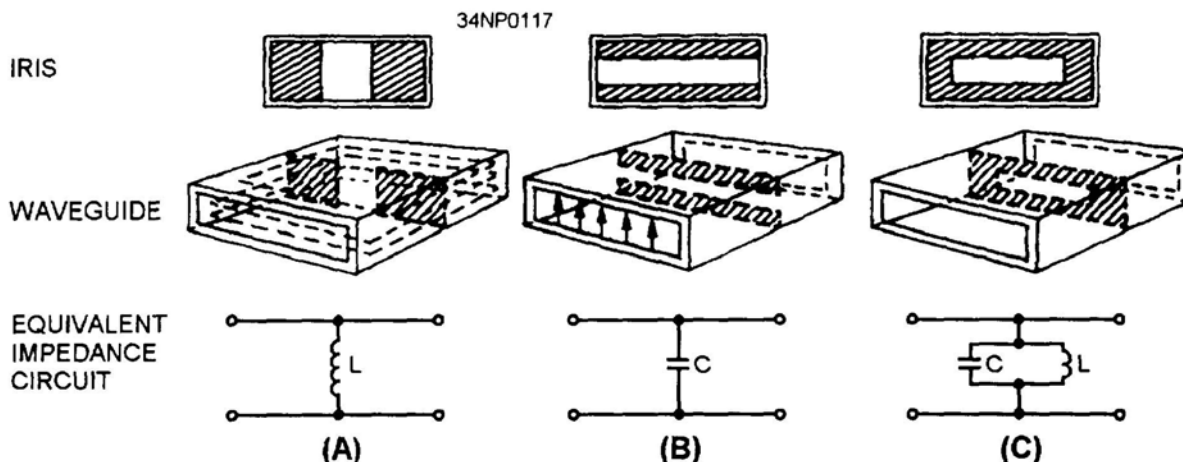

Figure 3-44.—Waveguide irises.



and electric transverse planes and forms an equivalent parallel-LC circuit across the waveguide. At the resonant frequency, the iris acts as a high shunt resistance. Above or below resonance, the iris acts as a capacitive or inductive reactance.

POSTS and SCREWS made from conductive material can be used for impedance-changing devices in waveguides. Views A and B of figure 3-45, illustrate two basic methods of using posts and screws. A post or screw that only partially penetrates into the waveguide acts as a shunt capacitive reactance. When the post or screw extends completely through the waveguide, making contact with the top and bottom walls, it acts as an inductive reactance. Note that when screws are used, the amount of reactance can be varied.

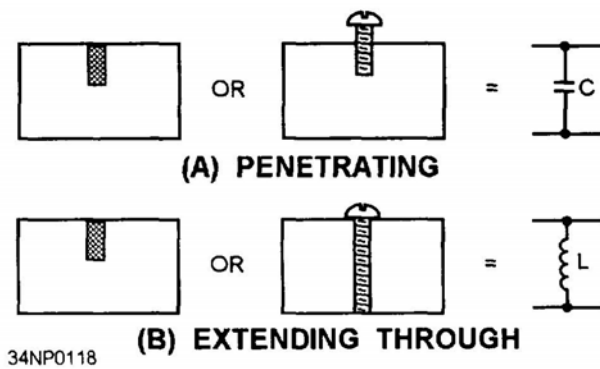

Figure 3-45.—Conducting posts and screws.

### WAVEGUIDE TERMINATIONS

Electromagnetic energy is often passed through a waveguide to transfer the energy from a source into space. As previously mentioned, the impedance of a waveguide does not match the impedance of space, and without proper impedance matching standing waves cause a large decrease in the efficiency of the waveguide.

Any abrupt change in impedance causes standing waves, but when the change in impedance at the end of a waveguide is gradual, almost no standing waves are formed. Gradual changes in impedance can be obtained by terminating the waveguide with a funnel-shaped HORN, such as the three types illustrated in figure 3-46. The type of horn used depends upon the frequency and the desired radiation pattern.

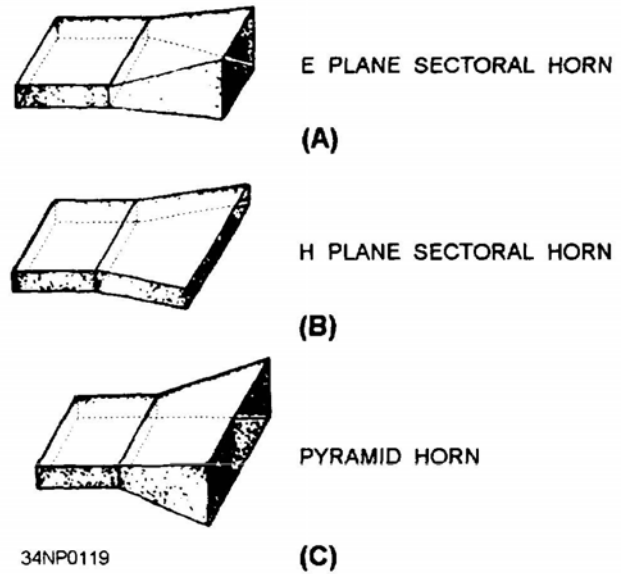

Figure 3-46.—Waveguide horns.

As you may have noticed, horns are really simple antennas. They have several advantages over other impedance-matching devices, such as their large bandwidth and simple construction.

A waveguide may also be terminated in a resistive load that is matched to the characteristic impedance of the waveguide. The resistive load is most often called a DUMMY LOAD, because its only purpose is to absorb all the energy in a waveguide without causing standing waves.

There is no place on a waveguide to connect a fixed termination resistor; therefore, several special arrangements are used to terminate waveguides. One method is to fill the end of the waveguide with a graphite and sand mixture, as illustrated in figure 3-47, view A. When the fields enter the mixture, they induce a current flow in the mixture that dissipates the energy as heat. Another method (view B) is to use a high-resistance rod placed at the center of the E field. The E field causes current to flow in the rod, and the high resistance of the rod dissipates the energy as a power loss, again in the form of heat.

Still another method for terminating a waveguide is the use of a wedge of highly resistive material, as shown in view C of figure 3-47. The plane of the wedge is placed perpendicular to the magnetic lines

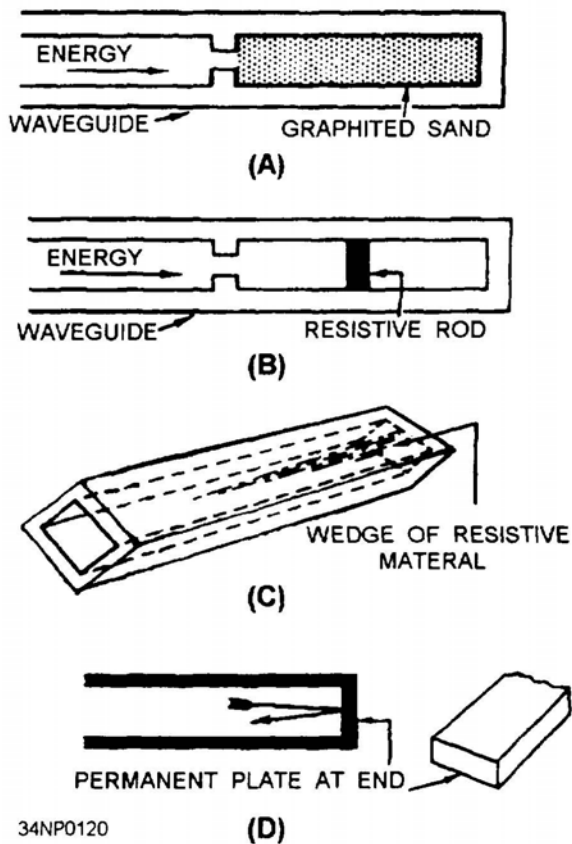

Figure 3-47.—Terminating waveguides.

of force. When the H lines cut through the wedge, current flows in the wedge and causes a power loss. As with the other methods, this loss is in the form of heat. Since very little energy reaches the end of the waveguide, reflections are minimum.

All of the terminations discussed so far are designed to radiate or absorb the energy without reflections. In many instances, however, all of the energy must be reflected from the end of the waveguide. The best way to accomplish this is to permanently weld a metal plate at the end of the waveguide, as shown in view D of figure 3-47.

### WAVEGUIDE PLUMBING

Since waveguides are really only hollow metal pipes, the installation and the physical handling of waveguides have many similarities to ordinary plumbing. In light of this fact, the bending, twisting, joining, and installation of waveguides is commonly called waveguide plumbing. Naturally, waveguides are different in design from pipes that are designed

to carry liquids or other substances. The design of a waveguide is determined by the frequency and power level of the electromagnetic energy it will carry. The following paragraphs explain the physical factors involved in the design of waveguides.

### Waveguide Bends

The size, shape, and dielectric material of a waveguide must be constant throughout its length for energy to move from one end to the other without reflections. Any abrupt change in its size or shape can cause reflections and a loss in overall efficiency. When such a change is necessary, the bends, twists, and joints of the waveguides must meet certain conditions to prevent reflections.

Waveguides maybe bent in several ways that do not cause reflections. One way is the gradual bend shown in figure 3-48. This gradual bend is known as an E bend because it distorts the E fields. The E bend must have a radius greater than two wavelengths to prevent reflections.

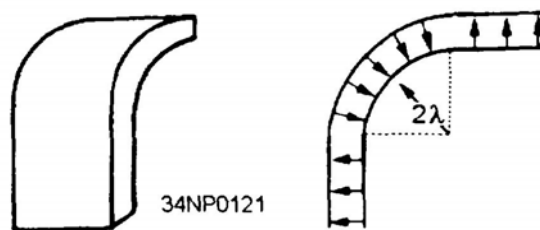

Figure 3-48.—Gradual E bend.

Another common bend is the gradual H bend (fig. 3-49). It is called an H bend because the H fields are distorted when a waveguide is bent in this manner. Again, the radius of the bend must be greater than two wavelengths to prevent reflections. Neither the E bend in the “a” dimension nor the H bend in the “b” dimension changes the normal mode of operation.

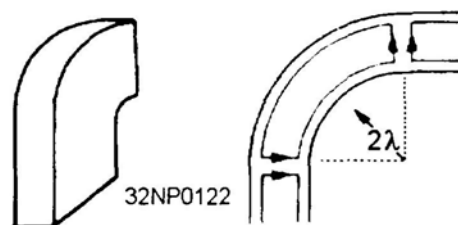

Figure 3-49.—Gradual H bend.

A sharp bend in either dimension may be used if it meets certain requirements. Notice the two 45-degree bends in figure 3-50; the bends are  $1/4\lambda$  apart. The reflections that occur at the 45-degree bends cancel each other, leaving the fields as though no reflections have occurred.

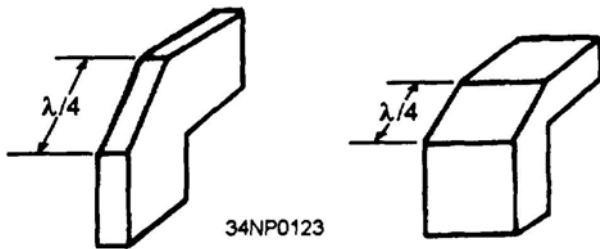

Figure 3-50.—Sharp bends.

Sometimes the electromagnetic fields must be rotated so that they are in the proper phase to match the phase of the load. This may be accomplished by twisting the waveguide as shown in figure 3-51. The twist must be gradual and greater than  $2\lambda$ .

Figure 3-50.—Sharp bends.

Sometimes the electromagnetic fields must be rotated so that they are in the proper phase to match the phase of the load. This may be accomplished by twisting the waveguide as shown in figure 3-51. The twist must be gradual and greater than  $2\lambda$ .

Figure 3-51.—Waveguide twist.

The flexible waveguide (fig. 3-52) allows special bends, which some equipment applications might require. It consists of a specially wound ribbon of conductive material, the most commonly used is brass, with the inner surface plated with chromium. Power losses are greater in the flexible waveguide because the inner surfaces are not perfectly smooth. Therefore, it is only used in short sections where no other reasonable solution is available.

### Waveguide Joints

Since an entire waveguide system cannot possibly be molded into one piece, the waveguide must be

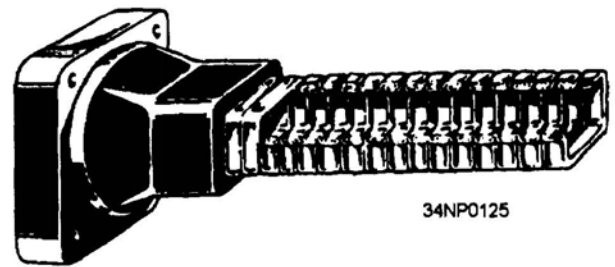

Figure 3-52.—Flexible waveguide.

constructed in sections and the sections connected with joints. The three basic types of waveguide joints are the PERMANENT, the SEMIPERMANENT, and the ROTATING JOINTS. Since the permanent joint is a factory-welded joint that requires no maintenance, only the semipermanent and rotating joints will be discussed.

Sections of waveguide must be taken apart for maintenance and repair. A semipermanent joint, called a CHOKE JOINT, is most commonly used for this purpose. The choke joint provides good electromagnetic continuity between the sections of the waveguide with very little power loss.

A cross-sectional view of a choke joint is shown in figure 3-53. The pressure gasket shown between the two metal surfaces forms an airtight seal. Notice in view B that the  $1/4\lambda$  from the “a” wall of the waveguide. The slot is also  $1/4\lambda$  deep, as shown in view A, and because it is shorted at point 1, a high impedance results at point 2. Point 3 is from point 2. The high impedance at point 2 results in a low impedance, or short, at point 3. This effect creates a good electrical connection between the two sections that permits energy to pass with very little reflection or loss.

Whenever a stationary rectangular waveguide is to be connected to a rotating antenna, a rotating joint must be used. A circular waveguide is normally used in a rotating joint. Rotating a rectangular waveguide would cause field pattern distortion. The rotating section of the joint, illustrated in figure 3-54, uses a choke joint to complete the electrical connection with the stationary section. The circular waveguide is designed so that it will operate in the  $TM_{0,1}$  mode.

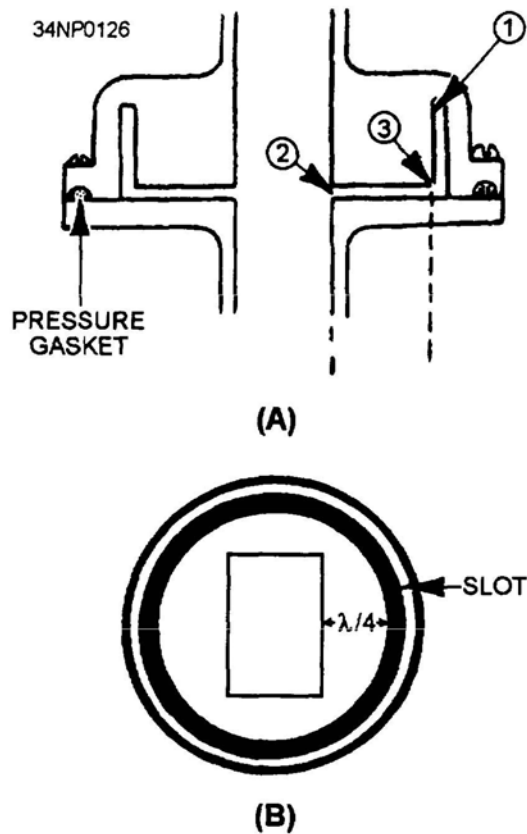

Figure 3-53.—Choke joint.

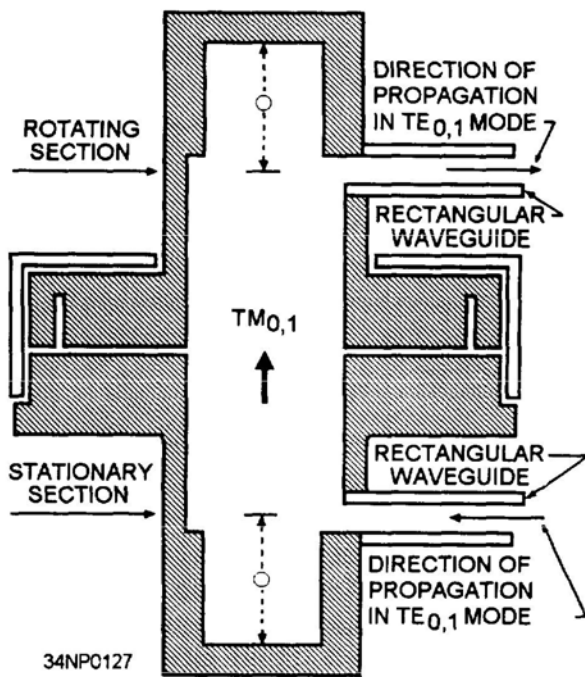

Figure 3-54.—Rotating joint.

The rectangular sections are attached as shown in the illustration to prevent the circular waveguide from operating in the wrong mode. Distance "O" is so that a high impedance will be presented to any unwanted modes. This is the most common design used for rotating joints, but other types may be used in specific applications.

### WAVEGUIDE MAINTENANCE

The installation of a waveguide system presents problems that are not normally encountered when dealing with other types of transmission lines. These problems often fall within the technician's area of responsibility. A brief discussion of waveguide handling, installation, and maintenance will help prepare you for this maintenance responsibility. Detailed information concerning waveguide maintenance in a particular system may be found in the technical manuals for the system.

Since a waveguide naturally has a low loss ratio, most losses in a waveguide system are caused by other factors. Improperly connected joints or damaged inner surfaces can decrease the efficiency of a system to the point that it will not work at all. Therefore, you must take great care when working with waveguides to prevent physical damage. Since waveguides are made from a soft, conductive material, such as copper or aluminum, they are very easy to dent or deform. Even the slightest damage to the inner surface of a waveguide will cause standing waves and, often, internal arcing. Internal arcing causes further damage to the waveguide in an action that is often self-sustaining until the waveguide is damaged beyond use. Part of your job as a technician will be to inspect the waveguide system for physical damage. The previously mentioned dents are only one type of physical damage that can decrease the efficiency of the system. Another problem occurs because waveguides are made from a conductive material such as copper while the structures of most ships are made from steel. When two dissimilar metals, such as copper and steel, are in direct contact, an electrical action called ELECTROLYSIS takes place that causes very rapid corrosion of the metals. Waveguides can be completely destroyed by electrolytic corrosion in a relatively short period of time if they are not isolated from direct contact with other metals. Any inspection

of a waveguide system should include a detailed inspection of all support points to ensure that electrolytic corrosion is not taking place. Any waveguide that is exposed to the weather should be painted and all joints sealed. Proper painting prevents natural corrosion, and sealing the joints prevents moisture from entering the waveguide.

Moisture can be one of the worst enemies of a waveguide system. As previously discussed, the dielectric in waveguides is air, which is an excellent dielectric as long as it is free of moisture. Wet air, however, is a very poor dielectric and can cause serious internal arcing in a waveguide system. For this reason, care is taken to ensure that waveguide systems are pressurized with air that is dry. Checking the pressure and moisture content of the waveguide air may be one of your daily system maintenance duties.

More detailed waveguide installation and maintenance information can be found in the technical manuals that apply to your particular system. Another good source is the *Electronics Installation and Maintenance Handbooks (EIMB)* published by Naval Sea Systems Command. *Installation Standards (EIMB) Handbook*, NAVSEA 0967-LP-000-0110, is the volume that deals with waveguide installation and maintenance.

## WAVEGUIDE DEVICES

The discussion of waveguides, up to this point, has been concerned only with the transfer of energy from one point to another. Many waveguide devices have been developed, however, that modify the energy in some fashion during the transmission. Some devices do nothing more than change the direction of the energy. Others have been designed to change the basic characteristics or power level of the electromagnetic energy.

This section will explain the basic operating principles of some of the more common waveguide devices, such as DIRECTIONAL COUPLERS, CAVITY RESONATORS, and HYBRID JUNCTIONS.

### Directional Couplers

The directional coupler is a device that provides a method of sampling energy from within a waveguide

for measurement or use in another circuit. Most couplers sample energy traveling in one direction only. However, directional couplers can be constructed that sample energy in both directions. These are called BIDIRECTIONAL couplers and are widely used in radar and communications systems.

Directional couplers may be constructed in many ways. The coupler illustrated in figure 3-55 is constructed from an enclosed waveguide section of the same dimensions as the waveguide in which the energy is to be sampled. The "b" wall of this enclosed section is mounted to the "b" wall of the waveguide from which the sample will be taken. There are two holes in the "b" wall between the sections of the coupler. These two holes are  $\lambda/4$  apart. The upper section of the directional coupler has a wedge of energy-absorbing material at one end and a pickup probe connected to an output jack at the other end. The absorbent material absorbs the energy not directed at the probe and a portion of the overall energy that enters the section.

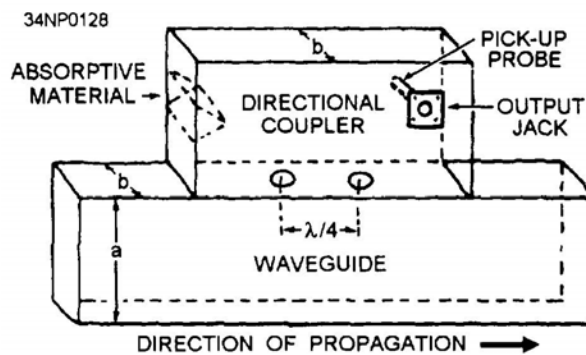

Figure 3-55.—Directional coupler.

Figure 3-56 illustrates two portions of the incident wavefront in a waveguide. The waves travel down the waveguide in the direction indicated and enter the coupler section through both holes. Since both portions of the wave travel the same distance, they are in phase when they arrive at the pickup probe. Because the waves are in phase, they add together and provide a sample of the energy traveling down the waveguide. The sample taken is only a small portion of the energy that is traveling down the waveguide. The magnitude of the sample, however, is proportional to the magnitude of the energy in the waveguide. The absorbent material is designed to ensure that the ratio

between the sample energy and the energy in the waveguide is constant. Otherwise, the sample would contain no useful information. The ratio is usually stamped on the coupler in the form of an attenuation factor.

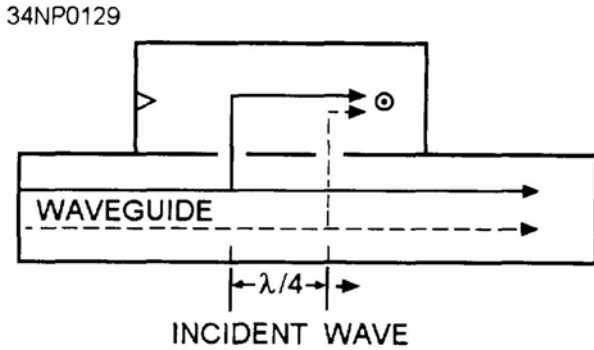

Figure 3-56.—Incident wave in a directional coupler designed to sample incident waves.

and the probe are in opposite positions from the directional coupler designed to sample the incident energy. This positioning causes the two portions of the reflected energy to arrive at the probe in phase, providing a sample of the reflected energy. The transmitted energy is absorbed by the absorbent material.

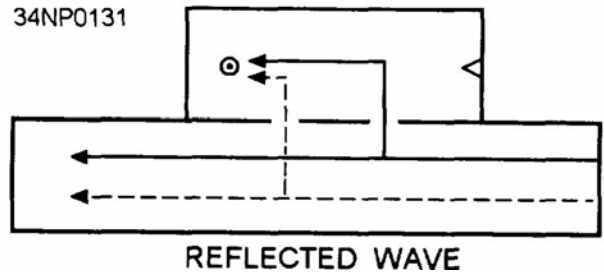

Figure 3-58.—Directional coupler designed to sample reflected energy.

The effect of a directional coupler on any reflected energy is illustrated in figure 3-57. Note that these two waves do not travel the same distance to the pickup probe. The wave represented by the dotted line travels  $1\frac{1}{2}\lambda$  further and arrives at the probe 180 degrees out of phase with the wave, represented by the solid line. Because the waves are 180 degrees out of phase at the probe, they cancel each other and no energy is induced into the pickup probe. When the reflected energy arrives at the absorbent material, it adds and is absorbed by the material.

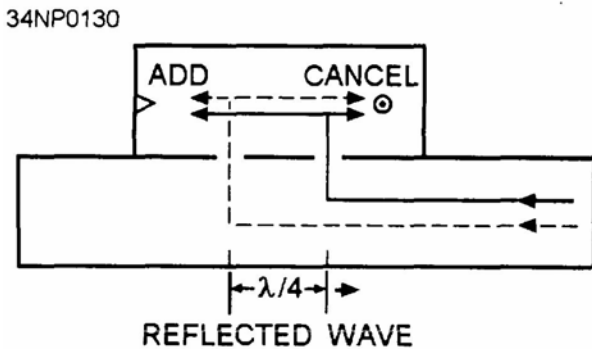
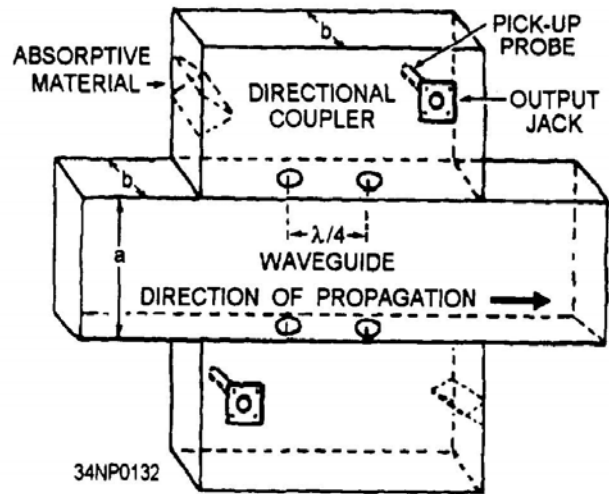

Figure 3-57.—Reflected wave in a directional coupler.

A simple bidirectional coupler for sampling both transmitted and reflected energy can be constructed by mounting two directional couplers on opposite sides of a waveguide, as shown in figure 3-59.



### Cavity Resonators

By definition, a resonant cavity is any space completely enclosed by conducting walls that can contain oscillating electromagnetic fields and possess resonant properties. The cavity has many advantages

A directional coupler designed to sample reflected energy is shown in figure 3-58. The absorbent material



and uses at microwave frequencies. Resonant cavities have a very high Q and can be built to handle relatively large amounts of power. Cavities with a Q value in excess of 30,000 are not uncommon. The high Q gives these devices a narrow bandpass and allows very accurate tuning. Simple, rugged construction is an additional advantage.

Although cavity resonators, built for different frequency ranges and applications, have a variety of shapes, the basic principles of operation are the same for all.

One example of a cavity resonator is the rectangular box shown in figure 3-60, view A. It may be thought of as a section of rectangular waveguide closed at both ends by conducting plates. The frequency at which the resonant ~~1/2~~ occurs is the distance between the end plates. The magnetic field patterns in the rectangular cavity are shown in view B.

There are two variables that determine the primary frequency of any resonant cavity. The first variable is PHYSICAL SIZE. In general, the smaller the cavity, the higher its resonant frequency. The second controlling factor is the SHAPE of the cavity. Figure 3-61 illustrates several cavity shapes that are commonly used. Remember from the previously stated definition of a resonant cavity that any completely enclosed conductive surface, regardless of its shape, can act as a cavity resonator.

Energy can be inserted or removed from a cavity by the same methods that are used to couple energy into and out of waveguides. The operating principles of probes, loops, and slots are the same whether used in a cavity or a waveguide. Therefore, any of the three methods can be used with cavities to inject or remove energy.

The resonant frequency of a cavity can be varied by changing any of the three parameters: cavity volume, cavity capacitance, or cavity inductance. Changing the frequencies of a cavity is known as TUNING. The mechanical methods of tuning a cavity may vary with the application, but all methods use the same electrical principles.

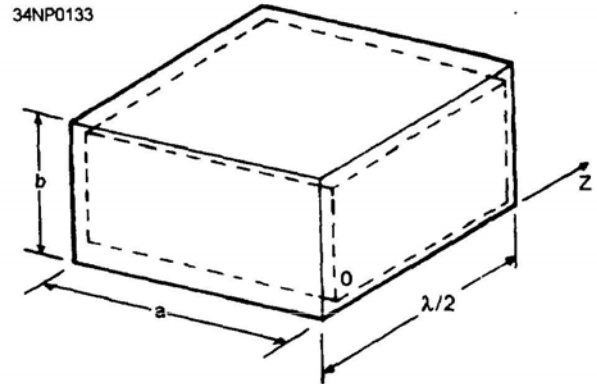

(A) RESONATOR SHAPE

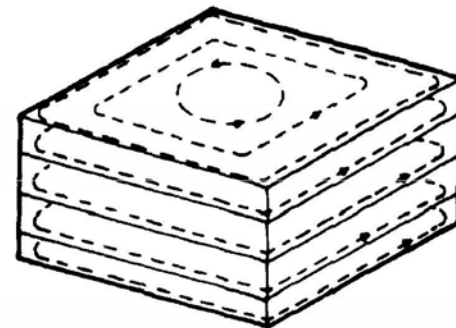

MAGNETIC FIELD PATTERN

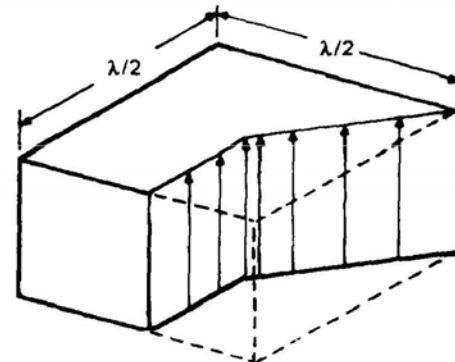

ELECTRIC FIELD PATTERN

(B) FIELD PATTERNS OF A SIMPLE MODE

Figure 3-60.—Rectangular waveguide cavity resonator.

### Waveguide Junctions

You may have assumed that when energy traveling down a waveguide reaches a junction it simply divides and follows the junction. This is not strictly true.

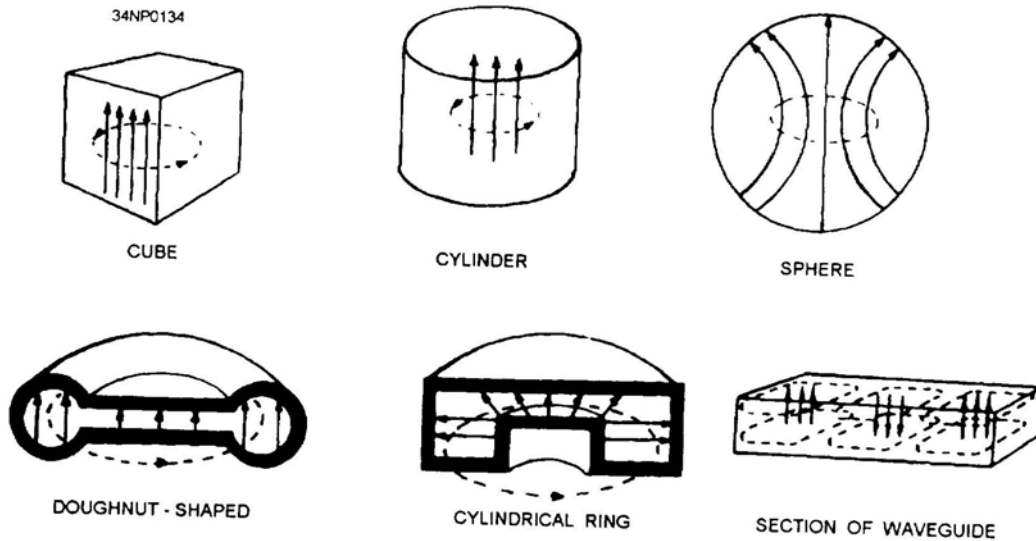

Figure 3-61.—Types of cavities.

Different types of junctions affect the energy in different ways. Since waveguide junctions are used extensively in most systems, you need to understand the basic operating principles of those most commonly used.

divided into two basic types, the E TYPE and the H TYPE. HYBRID JUNCTIONS are more complicated developments of the basic T junctions. The MAGIC-T and the HYBRID RING are the two most commonly used hybrid junctions.

The T JUNCTION is the most simple of the commonly used waveguide junctions. T junctions are

**E-TYPE T JUNCTION.**— An E-type T junction is illustrated in figure 3-62, view A.

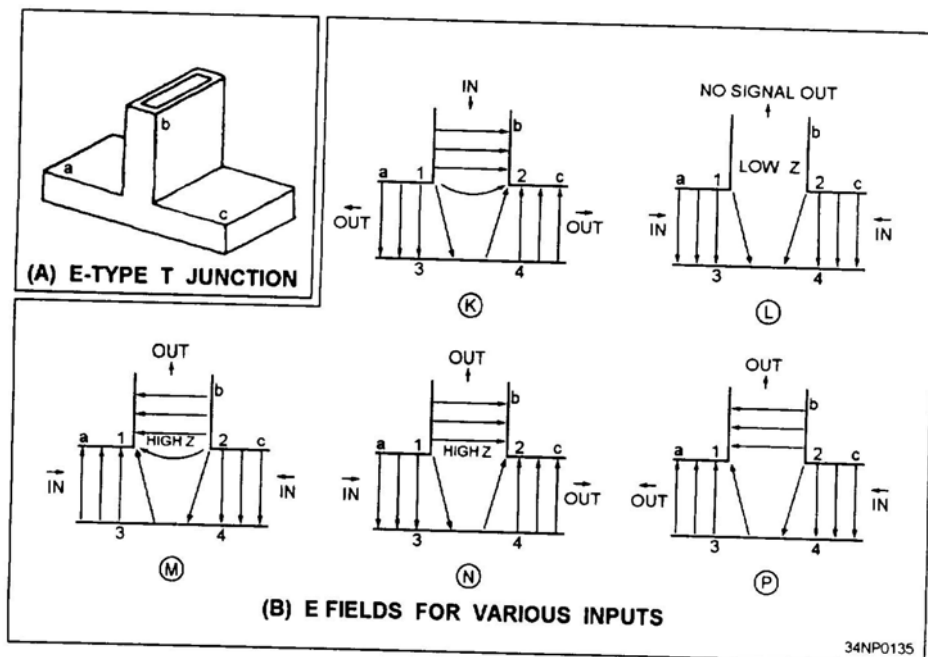

Figure 3-62.—E fields in an E-type T junction.



It is called an E-type T junction because the junction arm extends from the main waveguide in the same direction as the E field in the waveguide.

Figure 3-62, view B, illustrates cross-sectional views of the E-type T junction with inputs fed into the various arms. For simplicity, the magnetic lines that are always present with an electric field have been omitted. In view K, the input is fed into arm b and the outputs are taken from the a and c arms. When the E field arrives between points 1 and 2, point 1 becomes positive and point 2 becomes negative. The positive charge at point 1 then induces a negative charge on the wall at point 3. The negative charge at point 2 induces a positive charge at point 4. These charges cause the fields to form 180 degrees out of phase in the main waveguide; therefore, the outputs will be 180 degrees out of phase with each other. In view L, two in-phase inputs of equal amplitude are fed into the a and c arms. The signals at points 1 and

2 have the same phase and amplitude. No difference of potential exists across the entrance to the b arm, and no energy will be coupled out. However, when the two signals fed into the a and c arms are 180 degrees out of phase, as shown in view M, points 1 and 2 have a difference of potential. This difference of potential induces an E field from point 1 to point 2 in the b arm, and energy is coupled out of this arm. Views N and P illustrate two methods of obtaining two outputs with only one input.

**H-TYPE T JUNCTION.**— An H-type T junction is illustrated in figure 3-63, view A. It is called an H-type T junction because the long axis of the “b” arm is parallel to the plane of the magnetic lines of force in the waveguide. Again, for simplicity, only the E lines are shown in this figure. Each X indicates an E line moving away from the observer. Each dot indicates an E line moving toward the observer.

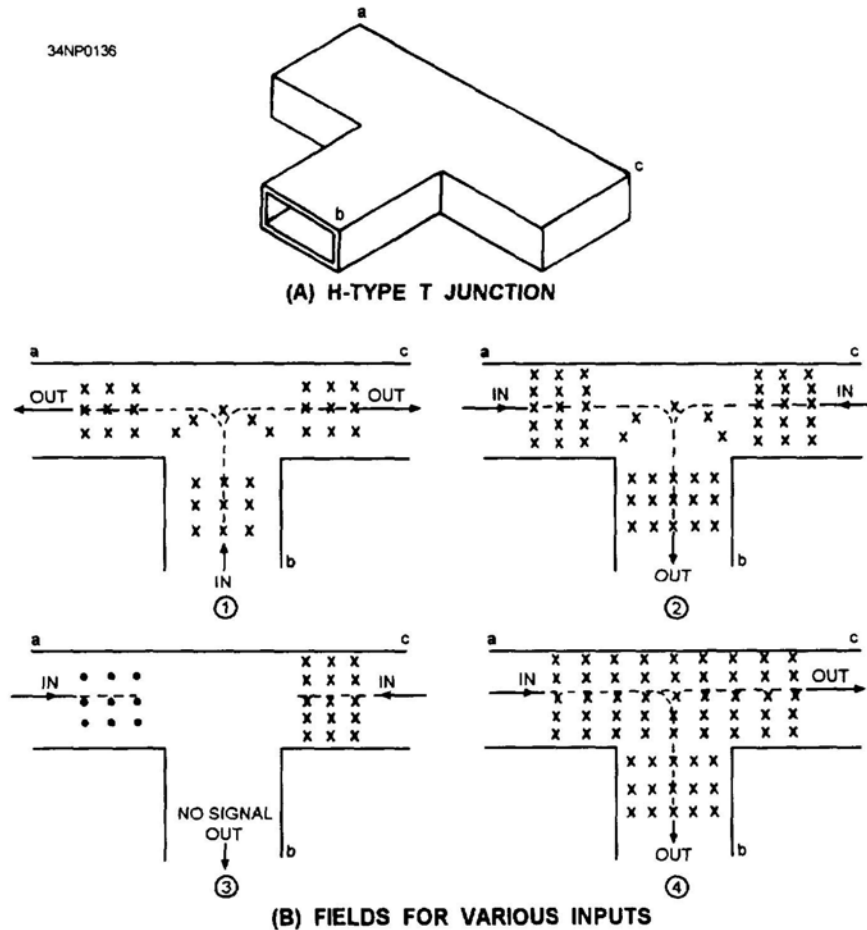

Figure 3-63.—E field in an H-type T junction.

In view 1 of figure 3-63, view B, the signal is fed into arm b and in-phase outputs are obtained from the a and c arms. In view 2, in-phase signals are fed into arms a and c and the output signal is obtained from the b arm because the fields add at the junction and induce E lines into the b arm. If 180-degree-out-of-phase signals are fed into arms a and c, as shown in view 3, no output is obtained from the b arm because the opposing fields cancel at the junction. If a signal is fed into the a arm, as shown in view 4, outputs will be obtained from the b and c arms. The reverse is also true. If a signal is fed into the c arm, outputs will be obtained from the a and b arms.

**MAGIC-T HYBRID JUNCTION.**— A simplified version of the magic-T hybrid junction is shown in figure 3-64. The magic-T is a combination of the H-type and E-type T junctions. The most common application of this type of junction is as the mixer section for microwave radar receivers.

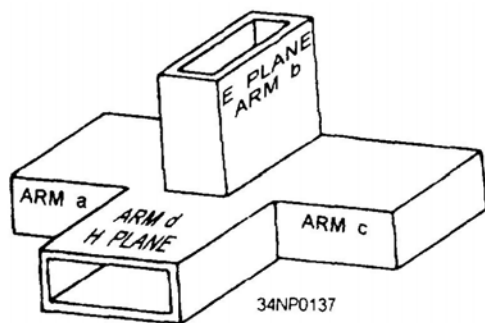

Figure 3-64.—Magic-T hybrid junction.

If a signal is fed into the b arm of the magic-T, it will divide into two out-of-phase components. As shown in figure 3-65, view A, these two components will move into the a and c arms. The signal entering the b arm will not enter the d arm because of the zero potential existing at the entrance of the d arm. The potential must be zero at this point to satisfy the boundary conditions of the b arm. This absence of potential is illustrated in views B and C where the magnitude of the E field in the b arm is indicated by the length of the arrows. Since the E lines are at maximum in the center of the b arm and minimum at the edge where the d arm entrance is located, no potential difference exists across the mouth of the d arm.

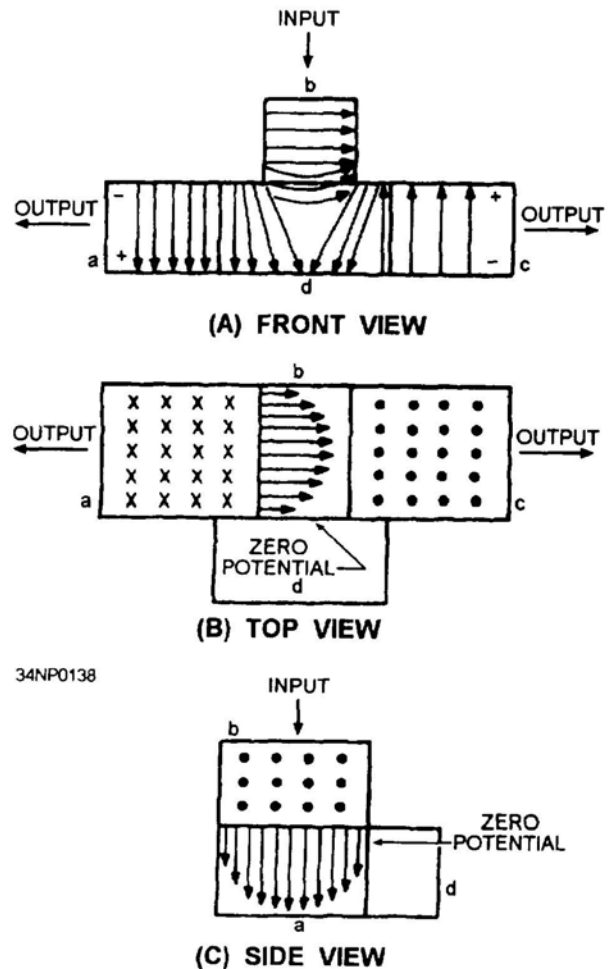

Figure 3-65.—Magic-T with input to arm b.

In summary, when an input is applied to arm b of the magic-T hybrid junction, the output signals from arms a and c are 180 degrees out of phase with each other, and no output occurs at the d arm.

The action that occurs when a signal is fed into the d arm of the magic-T is illustrated in figure 3-66. As with the H-type T junction, the signal entering the d arm divides and moves down the a and c arms as outputs that are in phase with each other and with the input. The shape of the E fields in motion is shown by the numbered curved slices. As the E field moves down the d arm, points 2 and 3 are at an equal potential. The energy divides equally into arms a and c, and the E fields in both arms become identical in shape. Since the potentials on both sides of the b arm are equal, no potential difference exists at the entrance to the b arm, resulting in no output.

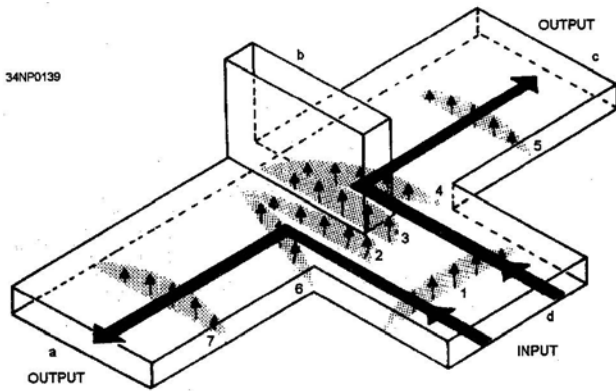

Figure 3-66.—Magic-T with input to arm d.

When an input signal is fed into the a arm as shown in figure 3-67, a portion of the energy is coupled into the b arm as it would be in an E-type T junction. An equal portion of the signal is coupled through the d arm because of the action of the H-type junction. The c arm has two fields across it that are out of phase with each other. Therefore, the fields cancel, resulting in no output at the c arm. The reverse of this action takes place if a signal is fed into the c arm, resulting in outputs at the b and d arms and no output at the a arm.

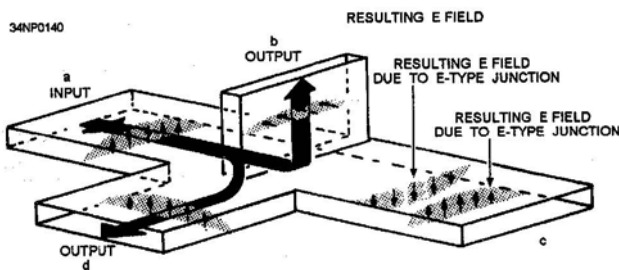

Figure 3-67.—Magic-T with input to arm a.

Unfortunately, when a signal is applied to any arm of a magic-T, the flow of energy in the output arms is affected by reflections. Reflections are caused by impedance mismatching at the junctions. These reflections are the cause of the two major disadvantages of the magic-T. First, the reflections represent a power loss since all the energy fed into the junction does not reach the load that the arms feed. Second, the reflections produce standing waves that can result in internal arcing. Thus, the maximum power a magic-T can handle is greatly reduced.

Reflections can be reduced by using some means of impedance matching that does not

destroy the shape of the junctions. One method is shown in figure 3-68. A post is used to match the H plane, and an iris is used to match the E plane. Even though this method reduces reflections, it lowers the power-handling capability even further.

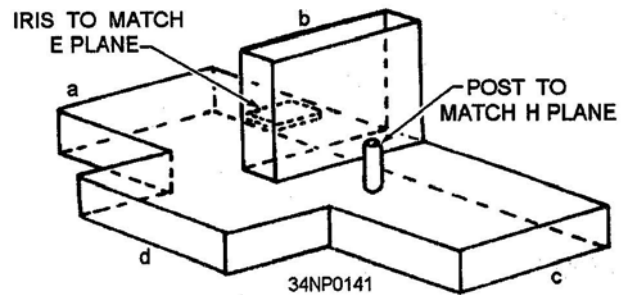

Figure 3-68.—Magic-T impedance matching.

**HYBRID RING.**— A type of hybrid junction that overcomes the power limitation of the magic-T is the hybrid ring, also called a RAT RACE. The hybrid ring, illustrated in figure 3-69, view A, is actually a modification of the magic-T. It is constructed of rectangular waveguides molded into a circular pattern. The arms are joined to the circular waveguide to form E-type T junctions. View B shows, in wavelengths, the dimensions required for a hybrid ring to operate properly.

The hybrid ring is used primarily in high-powered radar and communications systems to perform two functions. During the transmit period, the hybrid ring couples microwave energy from the transmitter to the antenna and allows no energy to reach the receiver. During the receive cycle, the hybrid ring couples energy from the antenna to the receiver and allows no energy to reach the transmitter. Any device that performs both of these functions is called a DUPLEXER. A duplexer permits a system to use the same antenna for both transmitting and receiving.

## SUMMARY

This concludes our discussion on transmission lines and waveguides. In this volume you have been given a basic introduction on wave propagation from the time it leaves the transmitter to the point of reception. In volume 8 you will be introduced to a variety of electronic support systems.

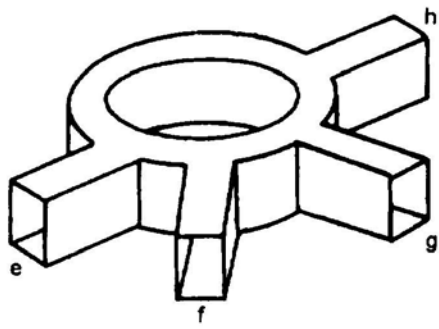

(A)

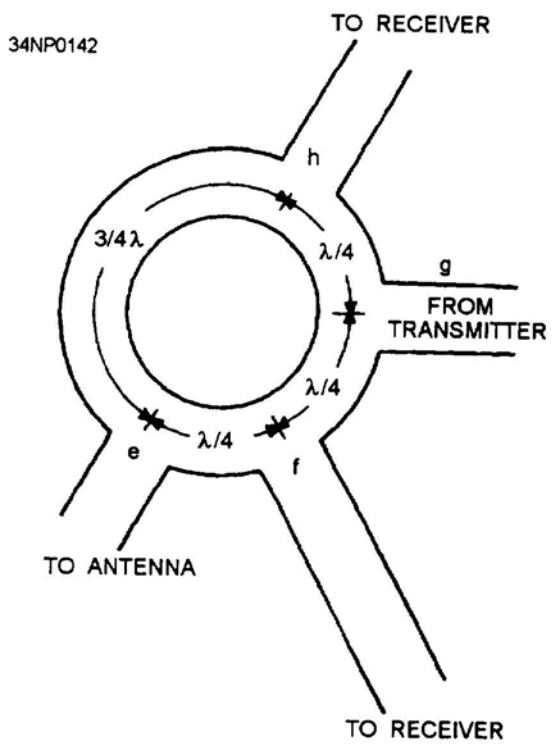

(B)

Figure 3-69.—Hybrid ring with wavelength measurements.

## APPENDIX I

# GLOSSAR

**ABSORPTION**—(1) Absorbing light waves. Does not allow any reflection or refraction; (2) Atmospheric absorption of rf energy with no reflection or refraction (adversely affects long-distance communications).

**ACOUSTICS**—The science of sound.

**AMPLITUDE**—The portion of a cycle measured from a reference line to a maximum value above (or to a maximum value below) the line.

**ANGLE OF INCIDENCE**—The angle between the incident wave and the normal.

**ANGLE OF REFLECTION**—The angle between the reflected wave and the normal.

**ANGLE OF REFRACTION**—The angle between the normal and the path of a wave through the second medium.

**ANGSTROM UNIT**—The unit used to define the wavelength of light waves.

**ANISOTROPIC**—The property of a radiator to emit strong radiation in one direction.

**ANTENNA**—A conductor or set of conductors used either to radiate rf energy into space or to collect rf energy from space.

**APERTURE**—See **SLOT**.

**ARRAY OF ARRAYS**—See **COMBINATION ARRAY**.

**BAY**—Part of an antenna array.

**BEARING**—An angular measurement that indicates the direction of an object in degrees from true north. Also called azimuth.

**BEVERAGE ANTENNA**—A horizontal, longwire antenna designed for reception and transmission of low-frequency, vertically polarized ground waves. Also known as **WAVE ANTENNA**.

**BIDIRECTIONAL ARRAY**—An array that radiates in opposite directions along the line of maximum radiation.

**BROADSIDE ARRAY**—An array in which the direction of maximum radiation is perpendicular to the plane containing the elements.

**BOUNDARY CONDITIONS**—The two conditions that the E-field and H-field within a waveguide must meet before energy will travel down the waveguide. The E-field must be perpendicular to the walls and the H-field must be in closed loops, parallel to the walls, and perpendicular to the E-field.

**CAVITY RESONATOR**—A space totally enclosed by a metallic conductor and supplied with energy in such a way that it becomes a source of electromagnetic oscillations. The size and shape of the enclosure determine the resonant frequency.

**CENTER-FEED METHOD**—Connecting the center of an antenna to a transmission line, which is then connected to the final (output) stage of the transmitter. Also known as **CURRENT-FEED METHOD**.

**CHARACTERISTIC IMPEDANCE**—The ratio of voltage to current at any given point on a transmission line. Represented by a value of impedance.

**CHOKE JOINT**—A joint between two sections of waveguide that provides a good electrical connection without power losses or reflections.

**COAXIAL LINE**—A type of transmission line that contains two concentric conductors.

**COLLINEAR ARRAY**—An array with all the elements in a straight line. Maximum radiation is perpendicular to the axis of the elements.

**COMBINATION ARRAY**—An array system that uses the characteristics of more than one array. Also known as **ARRAY OF ARRAYS**.

**COMPLEX WAVE**—A wave produced by combining two or more pure tones at the same time.

**CONDUCTANCE**—The opposite of resistance in transmission lines. The minute amount of resistance that is present in the insulator of a transmission line.

**CONNECTED ARRAY**—see **DRIVEN ARRAY**

**COPPER LOSS**—Power loss in copper conductors caused by the internal resistance of the conductors to current flow. Also known as **IR LOSS**.

**CORNER-REFLECTOR ANTENNA**—A half-wave antenna with a reflector consisting of two flat metal surfaces meeting at an angle behind the radiator.

**COUNTERPOISE**—A network of wire that is connected to a quarter-wave antenna at one end and provides the equivalent of an additional  $\frac{1}{4}$  wavelength.

**COUPLING DEVICE**—A coupling coil that connects the transmitter to the feeder.

**CREST (TOP)**—The peak of the positive alternation (maximum value above the line) of a wave.

**CRITICAL ANGLE**—The maximum angle at which radio waves can be transmitted and still be refracted back to earth.

**CRITICAL FREQUENCY**—The maximum frequency at which a radio wave can be transmitted vertically and still be refracted back to earth.

**CURRENT-FEED METHOD**—See **CENTER-FEED METHOD**.

**CURRENT STANDING-WAVE RATIO (ISWR)**—The ratio of maximum to minimum current along a transmission line.

**CUTOFF FREQUENCY**—The frequency at which the attenuation of a waveguide increases sharply and below which a traveling wave in a given mode cannot be maintained. A frequency with a half wavelength that is greater than the wide dimension of a waveguide.

**CYCLE**—One complete alternation of a sine wave that has a maximum value above and a maximum value below the reference line.

**DAMPING**—Reduction of energy by absorption.

**DENSITY**—(1) The compactness of a substance;  
(2) Mass per unit volume.

**DETECTOR**—The device that responds to a wave or disturbance.

**DIELECTRIC HEATING**—The heating of an insulating material by placing it in a high frequency electric field.

**DIELECTRIC LOSSES**—The losses resulting from the heating effect on the dielectric material between conductors.

**DIELECTRIC CONSTANT**—The ratio of a given dielectric to the dielectric value of a vacuum.

**DIFFRACTION**—The bending of the paths of waves when the waves meet some form of obstruction.

**DIPOLE**—A common type of half-wave antenna made from a straight piece of wire cut in half. Each half operates at a quarter wavelength of the output.

**DIRECTIONAL.**—Radiation that varies with direction.

**DIRECTIONAL COUPLER**—A device that samples the energy traveling in a waveguide for use in another circuit.

**DIRECTOR**—The parasitic element of an array that reinforces energy coming from the driver toward itself.

**DIRECTIVITY**—The property of an array that causes more radiation to take place in certain directions than in others.

**DISTRIBUTED CONSTANTS**—The constants of inductance, capacitance, and resistance in a transmission line. The constants are spread along the entire length of the line and cannot be distinguished separately.

**DOMINANT MODE**—The easiest mode to produce in a waveguide, and also, the most efficient mode in terms of energy transfer.

**DOPPLER EFFECT**—The apparent change in frequency or pitch when a sound source moves either toward or away from a listener.

**DOUBLET**—Another name for the dipole antenna.

**DRIVEN ARRAY**—An array in which all of the elements are driven. Also known as **CONNECTED ARRAY**

**DRIVEN ELEMENT**—An element of an antenna (transmitting or receiving) that is connected directly to the transmission line.

**DUMMY LOAD**—A device used at the end of a transmission line or waveguide to convert transmitted energy into heat so no energy is radiated outward or reflected back.

**E-FIELD**—Electric field that exists when a difference in electrical potential causes a stress in the dielectric between two points. Also known as **ELECTRIC FIELD**.

**E-TYPE T-JUNCTION**—A waveguide junction in which the junction arm extends from the main

waveguide in the same direction as the E-field in the waveguide.

**ECHO**—The reflection of the original sound wave as it bounces off a distant surface.

**ELECTROMAGNETIC FIELD**—The combination of an electric (E) field and a magnetic (H) field.

**ELECTROMAGNETIC INTERFERENCE**—Manmade or natural interference that degrades the quality of reception of radio waves.

**ELECTROMAGNETIC RADIATION**—The radiation of radio waves into space.

**ELECTRIC FIELD**—See **E-FIELD**.

**ELEMENT**—A part of an antenna that can be either an active radiator or a parasitic radiator.

**END-FEED METHOD**—Connecting one end of an antenna through a capacitor to the final output stage of a transmitter. Also known as **VOLTAGE-FEED METHOD**.

**END-FIRE ARRAY**—An array in which the direction of radiation is parallel to the axis of the array.

**ELEVATION ANGLE**—The angle between the line of sight to an object and the horizontal plane.

**FADING**—Variations in signal strength by atmospheric conditions.

**FEEDER**—A transmission line that carries energy to the antenna.

**FLAT LINE**—A transmission line that has no standing waves. This line requires no special tuning device to transfer maximum power.

**FLEXIBLE COAXIAL LINE**—coaxial line made with a flexible inner conductor insulated from the outer conductor by a solid, continuous insulating material.

**FOLDED DIPOLE**—An ordinary half-wave antenna (dipole) that has one or more additional conductors connected across the ends parallel to each other.

**FOUR-ELEMENT ARRAY**—An array with three parasitic elements and one driven element.

**FREE-SPACE LOSS**—The loss of energy of a radio wave because of the spreading of the wavefront as it travels from the transmitter.

**FREQUENCY**—The number of cycles that occur in one second. Usually expressed in Hertz.

**FREQUENCY DIVERSITY**—Transmitting (and receiving) of radio waves on two different frequencies simultaneously.

**FRONT-TO-BACK RATIO**—The ratio of the energy radiated in the principal direction to the energy radiated in the opposite direction.

**FUNDAMENTAL FREQUENCY**—The basic frequency or first harmonic frequency.

**GAIN**—The ratio between the amount of energy propagated from an antenna that is directional to the energy from the same antenna that would be propagated if the antenna were not directional.

**GENERATOR END**—See **INPUT END**

**GROUND PLANE**—The portion of a groundplane antenna that acts as ground.

**GROUND-PLANE ANTENNA**—A type of antenna that uses a ground plane as a simulated ground to produce low-angle radiation.

**GROUND REFLECTION LOSS**—The loss of rf energy each time a radio wave is reflected from the earth's surface.

**GROUND SCREEN**—A series of conductors buried below the surface of the earth and arranged in a radial pattern. Used to reduce losses in the ground.

**GROUND WAVES**—Radio waves that travel near the surface of the earth.

**GROUP VELOCITY**—The forward progress velocity of a wave front in a waveguide.

**H-FIELD**—Any space or region in which a magnetic force is exerted. The magnetic field may be produced by a current-carrying coil or conductor, by a permanent magnet, or by the earth itself. Also known as **MAGNETIC FIELD**.

**H-TYPE T-JUNCTION**—A waveguide junction in which the junction arm is parallel to the magnetic lines of force in the main waveguide.

**HALF-WAVE DIPOLE ANTENNA**—An antenna consisting of two rods ( $\frac{1}{2}$  wavelength  $h$ ) in a straight line, that radiates electromagnetic energy.

**HARMONIC**—A frequency that is a whole number multiple of a smaller base frequency.

**HERTZ ANTENNA**—A half-wave antenna installed some distance above ground and positioned either vertically or horizontally.

**HORN**—A funnel-shaped section of waveguide used as a termination device and as a radiating antenna.

**HORIZONTAL AXIS**—On a graph, the straight line axis plotted from left to right.

**HORIZONTAL PATTERN**—The part of a radiation pattern that is radiated in all directions along the horizontal plane.

**HORIZONTALLY POLARIZED**—Waves that are radiated with their E-field component parallel to the earth's surface.

**HYBRID JUNCTION**—A waveguide junction that combines two or more basic T-junctions.

**HYBRID RING**—A hybrid-waveguide junction that combines a series of E-type T-junctions in a ring configuration.

**IR LOSS**—See **COPPER LOSS**.



**INCIDENT WAVE**—(1) The wave that strikes the surface of a medium; (2) The wave that travels from the sending end to the receiving end of a transmission line.

**INDUCTION FIELD**—The electromagnetic field produced about an antenna when current and voltage are present on the same antenna.

**INDUCTION LOSSES**—The losses that occur when the electromagnetic field around a conductor cuts through a nearby metallic object and induces a current into that object.

**INPUT END**—The end of a two-wire transmission line that is connected to a source. Also known as a **GENERATOR END** or a **TRANSMITTER END**.

**INPUT IMPEDANCE**—The impedance presented to the transmitter by the transmission line and its load.

**INTERFERENCE**—Any disturbance that produces an undesirable response or degrades a wave.

**IONOSPHERE**—The most important region of the atmosphere extending from 31 miles to 250 miles above the earth. Contains four cloud-like layers that affect radio waves.

**IONOSPHERIC STORMS**—Disturbances in the earth's magnetic field that make communications practical only at lower frequencies.

**IONIZATION**—The process of upsetting electrical neutrality.

**IRIS**—A metal plate with an opening through which electromagnetic waves may pass. Used as an impedance matching device in waveguides.

**ISOTROPIC RADIATION**—The radiation of energy equally in all directions.

**LEAKAGE CURRENT**—The small amount of current that flows between the conductors of a transmission line through the dielectric.

**LOAD END**—See **OUTPUT END**.

**LOAD ISOLATOR**—A passive attenuator in which the loss in one direction is much greater than that in the opposite direction. An example is a ferrite isolator for waveguides that allow energy to travel in only one direction.

**LOADING**—See **LUMPED-IMPEDANCE TUNING**.

**LOBE**—An area of a radiation pattern plotted on a polar-coordinate graph that represents maximum radiation.

**LONG-WIRE ANTENNA**—An antenna that is a wavelength or more long at its operating frequency.

**LONGITUDINAL WAVES**—Waves in which the disturbance (back and forth motion) takes place in the direction of propagation. Sometimes called compression waves.

**LOOP**—(1) The curves of a standing wave or antenna that represent amplitude of current or voltage;

(2) A curved conductor that connects the ends of a coaxial cable or other transmission line and projects into a waveguide or resonant cavity for the purpose of injecting or extracting energy.

**LOWEST USABLE FREQUENCY**—The minimum operating frequency that can be used for communications between two points.

**LUMPED CONSTANTS**—The properties of inductance, capacitance, and resistance in a transmission line.

**LUMPED-IMPEDANCE TUNING**—The insertion of an inductor or capacitor in series with an antenna to lengthen or shorten the antenna electrically. Also known as **LOADING**.

**LOOSE COUPLING**—Inefficient coupling of energy from one circuit to another that is desirable in some applications. Also called weak coupling.

**MAGIC-T JUNCTION**—A combination of the H-type and E-type T-junctions.

**MAGNETIC FIELD**—See H-FIELD.

**MAJOR LOBE**—The lobe in which the greatest amount of radiation occurs.

**MARCONI ANTENNA**—A quarter-wave antenna oriented perpendicular to the earth and operated with one end grounded. Also known as **QUARTER-WAVE ANTENNA**.

**MAXIMUM USABLE FREQUENCY**—Maximum frequency that can be used for communications between two locations for a given time of day and a given angle of incidence.

**MEDIUM**—The substance through which a wave travels from one point to the next. Air, water, wood, etc., are examples of a medium.

**METALLIC INSULATOR**—A shorted quarter-wave section of transmission line.

**MICROWAVE REGION**—The portion of the electromagnetic spectrum from 1,000 megahertz to 100,000 megahertz.

**MINOR LOBE**—The lobe in which the radiation intensity is less than a major lobe.

**MULTIELEMENT ARRAY**—An array consisting of one or more arrays and classified as to directivity.

**MULTIELEMENT PARASITIC ARRAY**—An array that contains two or more parasitic elements and a driven element.

**MULTIPATH**—The multiple paths a radio wave may follow between transmitter and receiver.

**NEGATIVE ALTERNATION**—The portion of a sine wave below the reference line.

**NODE**—The fixed minimum points of voltage or current on a standing wave or antenna.

**NONDIRECTIONAL**—See **OMNIDIRECTIONAL**,

**NONRESONANT LINE**—A transmission line that has no standing waves of current or voltage.

**NORMAL**—The imaginary line perpendicular to the point at which the incident wave strikes the reflecting surface. Also called the perpendicular.

**NULL**—On a polar-coordinate graph, the area that represents minimum or 0 radiation.

**OMNIDIRECTIONAL**—Transmitting in all directions. Also known as **NONDIRECTIONAL**.

**OPEN-ENDED LINE**—A transmission line that has an infinitely large terminating impedance.

**OPTIMUM WORKING FREQUENCY**—The most practical operating frequency that can be used with the least amount of problems; roughly 85 percent of the maximum usable frequency.

**ORIGIN**—The point on a graph where the vertical and horizontal axes cross each other.

**OUTPUT END**—The end of a transmission line that is opposite the source. Also known as **RECEIVING END**.

**OUTPUT IMPEDANCE**—The impedance presented to the load by the transmission line and its source.

**PARALLEL RESONANT CIRCUIT**—A circuit that acts as a high impedance at resonance.

**PARALLEL-WIRE**—A type of transmission line consisting of two parallel wires.

**PARASITIC ARRAY**—An array that has one or more parasitic elements.

**PARASITIC ELEMENT**—The passive element of an antenna array that is connected to neither the transmission line nor the driven element.

**PERIOD**—The amount of time required for completion of one full cycle.

**PHASE SHIFTER**—A device used to change the phase relationship between two ac signals.

**PLANE OF POLARIZATION**—The plane (vertical or horizontal) with respect to the earth in which the E-field propagates.

**POSITIVE ALTERNATION**—The portion of a sine wave above the reference line.

**POWER GAIN**—The ratio of the radiated power of an antenna compared to the output power of a standard antenna. A measure of antenna efficiency usually expressed in decibels. Also referred to as **POWER RATIO**.

**POWER LOSS**—The heat loss in a conductor as current flows through it.

**POWER RATIO**—See **POWER GAIN**.

**POWER STANDING—WAVE RATIO (PSWR)**—The ratio of the square of the maximum and minimum voltages of a transmission line.

**PROPAGATION**—Waves traveling through a medium.

**PROBE**—A metal rod that projects into, but is insulated from, a waveguide or resonant cavity and used to inject or extract energy.

**QUARTER-WAVE ANTENNA**—See **MARCONI ANTENNA**.

**RADIATION FIELD**—The electromagnetic field that detaches itself from an antenna and travels through space.

**RADIATION LOSSES**—The losses that occur when magnetic lines of force about a conductor are projected into space as radiation and are not returned to the conductor as the cycle alternates.

**RADIATION PATTERN**—A plot of the radiated energy from an antenna.

**RADIATION RESISTANCE**—The resistance, which if inserted in place of an antenna, would consume the same amount of power as that radiated by the antenna.

**RADIO FREQUENCIES**—Electromagnetic frequencies that fall between 3 kilohertz and 300 gigahertz and are used for radio communications.

**RADIO HORIZON**—The boundary beyond the natural horizon in which radio waves cannot be propagated over the earth's surface.

**RADIO WAVE**—(1) A form of radiant energy that can neither be seen nor felt; (2) An electromagnetic wave generated by a transmitter.

**RAREFIED WAVE**—A longitudinal wave that has been expanded or rarefied (made less dense) as it moves away from the source.

**RECEIVER**—The object that responds to a wave or disturbance. Same as detector.

**RECEIVING ANTENNA**—The device used to pick up an rf signal from space.

**RECEIVING END**—See **OUTPUT END**.

**RECIPROCITY**—The ability of an antenna to both transmit and receive electromagnetic energy with equal efficiency.

**REFLECTED WAVE**—(1) The wave that reflects back from a medium; (2) Waves traveling from the load back to the generator on a transmission line; (3) The wave moving back to the sending end of a transmission line after reflection has occurred.

**REFLECTION WAVES**—Waves that are neither transmitted nor absorbed, but are reflected from the surface of the medium they encounter.

**REFLECTOR**—The parasitic element of an array that causes maximum energy radiation in a direction toward the driven element.

**REFRACTION**—The changing of direction as a wave leaves one medium and enters another medium of a different density.

**REFRACTIVE INDEX**—The ratio of the phase velocity of a wave in free space to the phase velocity of the wave in a given substance (dielectric).

**RERADIATION**—The reception and retransmission of radio waves caused by turbulence in the troposphere.

**RESONANCE**—The condition produced when the frequency of vibrations are the same as the natural frequency (of a cavity), The vibrations reinforce each other.

**RESONANT LINE**—A transmission line that has standing waves of current and voltage.

**RHOMBIC ANTENNA**—A diamond-shaped antenna used widely for long-distance, high-frequency transmission and reception.

**RIGID COAXIAL LINE**—A coaxial line consisting of a central, insulated wire (inner conductor) mounted inside a tubular outer conductor.

**ROTATING JOINT**—A joint that permits one section of a transmission line or waveguide to rotate continuously with respect to another while passing energy through the joint. Also called a rotary coupler.

**SCATTER ANGLE**—The angle at which the receiving antenna must be aimed to capture the scattered energy of tropospheric scatter.

**SELF-INDUCTION**—The phenomenon caused by the expanding and collapsing fields of an electron that encircles other electrons and retards the movement of the encircled electrons.

**SERIES RESONANT CIRCUIT**—A circuit that acts as a low impedance at resonance.

**SHIELDED PAIR**—A line consisting of parallel conductors separated from each other and surrounded by a solid dielectric.

**SHORT-CIRCUITED LINE**—A transmission line that has a terminating impedance equal to 0.

**SKIN EFFECT**—The tendency for alternating current to concentrate in the surface layer of a conductor. The effect increases with frequency and serves to increase the effective resistance of the conductor.

**SKIP DISTANCE**—The distance from a transmitter to the point where the sky wave is first returned to earth.

**SKIP ZONE**—A zone of silence between the point where the ground wave becomes too weak for reception and the point where the sky wave is first returned to earth.

**SKY WAVES**—Radio waves reflected back to earth from the ionosphere.

**SLOT**—Narrow opening in a waveguide wall used to couple energy in or out of the waveguide. Also called an **APERTURE** or a **WINDOW**.

**SOURCE**—(1) The object that produces waves or disturbance; (2) The name given to the end of a two-wire transmission line that is connected to a source.

**SPACE DIVERSITY**—Reception of radio waves by two or more antennas spaced some distance apart,

**SPACE WAVE**—A radio wave that travels directly from the transmitter to the receiver and remains in the troposphere.

**SPECTRUM**—(1) The entire range of electromagnetic waves; (2) **VISIBLE**. The range of electromagnetic waves that stimulate the sense of sight;

(3) **ELECTROMAGNETIC.** The entire range of electromagnetic waves arranged in order of their frequencies.

**SPORADIC E LAYER**—Irregular cloud-like patches of unusually high ionization. Often forms at heights near the normal E-layer.

**SPREADER**—Insulator used with transmission lines and antennas to keep the parallel wires separated.

**STANDING WAVE**—The distribution of voltage and current formed by the incident and reflected waves, which have minimum and maximum points on a resultant wave that appears to stand still.

**STANDING-WAVE RATIO (SWR)**—The ratio of the maximum to the minimum amplitudes of corresponding components of a field, voltage, or current along a transmission line or waveguide in the direction of propagation measured at a given frequency. Measures the perfection of the termination of the line.

**STRATOSPHERE**—Located between the troposphere and the ionosphere. Has little effect on radio waves.

**STUB**—Short section of a transmission line used to match the impedance of a transmission line to an antenna. Can also be used to produce desired phase relationships between connected elements of an antenna.

**SUDDEN IONOSPHERIC DISTURBANCE**—An irregular ionospheric disturbance that can totally blank out hf radio communications.

**SURFACE WAVE**—A radio wave that travels along the contours of the earth, thereby being highly attenuated.

**TEMPERATURE INVERSION**—The condition in which warm air is formed above a layer of cool air that is near the earth's surface.

**THREE-ELEMENT ARRAY**—An array with two parasitic elements (reflector and director) and a driven element.

**TRANSMISSION LINE**—A device designed to guide electrical energy from one point to another.

**TRANSMITTING ANTENNA**—The device used to send the transmitted signal energy into space.

**TRANSMISSION MEDIUMS**—The various types of lines and waveguides used as transmission lines.

**TRANSMITTER END**—See **INPUT END**.

**TRANSVERSE WAVE MOTION**—The up and down motion of a wave as the wave moves outward.

**TRANSVERSE ELECTRIC MODE**—The entire electric field in a waveguide is perpendicular to the wide dimension and the magnetic field is parallel to the length. Also called the TE mode.

**TRANSVERSE MAGNETIC MODE**—The entire magnetic field in a waveguide is perpendicular to the wide dimension ("a" wall) and some portion of the electric field is parallel to the length. Also called the TM mode.

**TROPOSPHERE**—The portion of the atmosphere closest to the earth's surface, where all weather phenomena take place.

**TROPOSPHERIC SCATTER**—The propagation of radio waves in the troposphere by means of scatter.

**TROUGH (BOTTOM)**—The peak of the negative alternation (maximum value below the line).

**TUNED LINE**—Another name for the resonant line. This line uses tuning devices to eliminate the reactance and to transfer maximum power from the source to the line.

**TURNSTILE ANTENNA**—A type of antenna used in vhf communications that is omnidirectional

and consists of two horizontal half-wave antennas mounted at right angles to each other in the same horizontal plane.

**TWISTED PAIR**—A line consisting of two insulated wires twisted together to form a flexible line without the use of spacers.

**TWO-WIRE OPEN LINE**—A parallel line consisting of two wires that are generally spaced from 2 to 6 inches apart by insulating spacers.

**TWO-WIRE RIBBON (TWIN LEAD)**—A parallel line similar to a two-wire open line except that uniform spacing is assured by embedding the two wires in a low-loss dielectric.

**UNIDIRECTIONAL ARRAY**—An array that radiates in only one general direction.

**UNTUNED LINE**—Another name for the flat or nonresonant line.

**V ANTENNA**—A bidirectional antenna, shaped like a V, which is widely used for communications.

**VELOCITY**—The rate at which a disturbance travels through a medium.

**VERTICAL AXIS**—On a graph, the straight line axis oriented from bottom to top.

**VERTICAL PATTERN**—The part of a radiation pattern that is radiated in the vertical plane.

**VERTICAL PLANE**—An imaginary plane that is perpendicular to the horizontal plane.

**VERTICALLY POLARIZED**—Waves radiated with the E-field component perpendicular to the earth's surface.

**VOLTAGE-FEED METHOD**—See **END-FEED METHOD**.

**VOLTAGE STANDING-WAVE RATIO (VSWR)**—The ratio of maximum to minimum voltage of a transmission line.

**WAVE ANTENNA**—See **BEVERAGE ANTENNA**.

**WAVE MOTION**—A recurring disturbance advancing through space with or without the use of a physical medium.

**WAVE TRAIN**—A continuous series of waves with the same amplitude and wavelength.

**WAVEFRONT**—A small section of an expanding sphere of electromagnetic radiation, perpendicular to the direction of travel of the energy.

**WAVEGUIDE**—A rectangular, circular, or elliptical metal pipe designed to transport electro-magnetic waves through its interior.

**WAVEGUIDE MODE OF OPERATION**—Particular field configuration in a waveguide that satisfies the boundary conditions. Usually divided into two broad types: the transverse electric (TE) and the transverse magnetic (TM).

**WAVEGUIDE POSTS**—A rod of conductive material used as impedance-changing devices in waveguides.

**WAVEGUIDE SCREW**—A screw that projects into a waveguide for the purpose of changing the impedance.

**WAVELENGTH**—(1) The distance in space occupied by 1 cycle of a radio wave at any given instant;  
(2) The distance a disturbance travels during one period of vibration.

**WINDOW**—See **Slot**.

**YAGI ANTENNA**—A multielement parasitic array. Elements lie in the same plane as those of the end-fire array.

# APPENDIX II REFERENCES USED TO DEVELOP THIS TRAMAN

Shipboard Antenna Systems, Vol 1, *Communications Antenna Fundamentals*, NAVSEA 0967-LP-177-3010, Naval Sea Systems Command, Washington, DC, 1972.

Shipboard Antenna Systems, Vol 2, *Installation Details Communications Antenna Systems*, NAVSEA 0967-LP-177-3020, Naval Sea Systems Command, Washington, DC, 1973.

Shipboard Antenna Systems, Vol 3, *Antenna Couplers Communications Antenna Systems*, NAVSEA 0967-LP-177-3030, Naval Sea Systems Command, Washington, DC, 1973.

Shipboard Antenna Systems, Vol 4, *Testing and Maintenance Communications Antenna Systems*, NAVSEA 0967-LP-177-3040, Naval Sea Systems Command, Washington, DC, 1972.

Navy Electricity and Electronics Training Series, Module 10, *Introduction to Wave Propagation, Transmission Lines, and Antennas*, NAVEDTRA B72-10-00-93, Naval Education and Training Program Management Support Activity, Pensacola FL, 1993.

Navy Electricity and Electronics Training Series, Module 11, *Microwave Principles*, NAVEDTRA 172-11-00-87, Naval Education and Training Program Management Support Activity, Pensacola FL, 1987.

Navy UHF Satellite Communication System Description, FSCS-200-83-1, Naval Ocean Systems Center, San Diego, CA, 1991.

# INDEX

## A

Antennas/antenna radiation anisotropic radiation, 2-4 characteristics, 2-1 counterpoise, 2-5, 2-6 directivity, 2-1 gain, 2-2 ground screen, 2-5, 2-6 Hertz antennas, 2-1 isotropic radiation, 2-4 loading, 2-4 lobe, 2-4 loop, 2-3 low probability of intercept (LPI), 2-19 lumped-impedance tuning, 2-5 major lobe, 2-4 Marconi antennas, 2-1 minor lobe, 2-4 node, 2-3, 3-9 period, 2-3 polarization, 2-2 reciprocity, 2-1 standing wave, 2-3 wavelength, 2-3

log-periodic (LPA), 2-8, 2-16 long-wire, 2-11 low frequency (lf), 2-7 NORD, 2-9 pan polar, 2-8 parasitic array, 2-7 quadrant, 2-11, 2-13 rhombic, 2-11, 2-12 rotatable LPA (RLPA), 2-10 sector log-periodic array, 2-10 Trideco, 2-7 tuning system, 2-13 ultra high frequency (uhf), 2-14 vertical monopole LPA, 2-8, 2-9 very high frequency (vhf), 2-14 very low frequency (vlf), 2-6 whip, 2-13, 2-14 wire rope fan, 2-14 Yagi, 2-7, 2-9

Atmosphere, 1-1 ionosphere, 1-1 stratosphere, 1-1 temperature inversion, 1-12 troposphere, 1-1 weather, 1-12

Coupler groups, 2-21 to 23 coupler group AN/SRA-33, 2-22 coupler group AN/SRA-39, 2-23 coupler group AN/SRA-40, 2-23 coupler group AN/SRA-49, 2-23 coupler group AN/SRA-49A, 2-23 coupler group AN/SRA-50, 2-23 coupler group AN/SRA-56, 2-21, 2-22 coupler group AN/SRA-57, 2-21, 2-22 coupler group AN/SRA-58, 2-21, 2-22 coupler group AN/URA-38, 2-21, 2-23 multicoupler (receive filter) AN/SR4-12, 2-23 multicoupler OA-9123/SRC, 2-22

Communications antennas, 2-6

biconical dipole, 2-15  
boom, 2-10  
center-fed dipole, 2-16  
coaxial dipole, 2-16, 2-17  
conical monopole, 2-11  
discage, 2-14, 2-15  
Goliath, 2-7  
ground plane, 2-10, 2-13  
high frequency (hf), 2-7  
inverted cone, 2-10, 2-11

## I

Ionosphere, 1-1 D layer, 1-3 E layer, 1-4 F/F1/F2 layer, 1-4 ionization 1-2 ionized layers, 1-2, 1-3 ionospheric storms, 1-11 ions, 1-2 regular variations, 1-1 seasonal variations, 1-10



solar flare, 1-4 sporadic E, 1-4, 1-11 sudden ionospheric disturbances (SID), 1-11 sunspot activity. 1-4, 1-10 sunspots cycles, 1-11

horn radiator, 2-25, 2-26 OE-172/SPS-55, 2-28 orange-peel paraboloid, 2-24, 2-25 parabolic reflector, 2-23 paraboloid, 2-24 truncated paraboloid, 2-24 AS-1669/SPN-35, 2-29, 2-30

## M

Matching networks, 2-20 antenna couplers, 2-21 antenna tuners, 2-20 antenna tuning, 2-21 receive distribution system, 2-22

RF safety, 2-30 dielectric heating, 2-30 radiation warning signs, 2-31 rf burns, 2-30 working aloft, 2-32

## P

Propagation, 1-4 angle of incidence 1-6, 3-14 angle of reflection  
( $\theta$ ), 3-14 critical angle, 1-6 critical frequency, 1-5, 1-11 escape point, 1-5 fading, 1-7 frequency diversity. 1-8 layer density, 1-5 multipath fading, 1-8 reflection, 1-7 refraction, 1-4 selective fading, 1-8 skip distance, 1-7 skip zone, 1-7 sky wave, 1-7 space diversity, 1-8

## S

Satellite communications antennas, 2-16 AN/WSC-6(V), 2-19, 2-20 Andrew 58622, 2-19 AS-2815/SRR-1, 2-16, 2-17 backplane, 2-17, 2-19 OE-82A/WSC-1(V), 2-17, 2-19 OE-82B/WSC-1(V), 2-16, 2-18 OE-82C/WSC-1(V), 2-16, 2-18

## T

Transmission, 1-12 absorption, 1-14 freespace losses, 1-13 frequency selection, 1-13 ground reflection losses, 1-13 lowest usable frequency (luf), 1-13 maximum usable frequency (muf), 1-13 optimum working frequency (fot), 1-14 plane wavefront, 2-23 wavefront, 1-13, 2-2, 2-23, 3-14

## R

Radar antennas, 2-23 AN/GPN-27 (ASR-8), 2-26 AN/SPN-35A, 2-29 AS-1292/TPN-8, 2-29 AS-32631SPS-49(V), 2-27 azimuth pulse generator (APG), 2-27 broadside array, 2-25 carrier-controlled approach (CCA), 2-29 corner reflector, 2-24, 2-25 cylindrical paraboloid, 2-24, 2-25 feedhorn, 2-26 focal point, 2-23 height-finding, 2-25

Transmission line, 3-1 ac, 3-5 capacitance, 3-1, 3-2 characteristic impedance ( $Z_0$ ), 3-3 coaxial line (flexible/rigid), 3-6, 3-7 conductance (G), 3-1, 3-2 copper losses (IR), 3-3, 3-9 current standing-wave ratio (iswr), 3-6 dc, 3-4, 3-5 dielectric losses, 3-3, 3-4, 3-9 distributed constants, 3-1

electric (E) field, 3-3, 3-12 electromagnetic fields, 3-3 incident wave, 3-5 inductance, 3-1, 3-2 induction losses, 3-3, 3-4 input impedance ( $Z_{in}$ ), 3-3 leakage current, 3-2 line losses, 3-3 lumped constants, 3-1 magnetic (H) field, 3-3, 3-12 output impedance ( $Z_{out}$ ), 3-3 parallel line, 3-6 power loss, 3-3 power standing-wave ratio (pswr), 3-6 radiation losses, 3-3, 3-4 reflected wave, 3-5 resistance, 3-1 self-induction, 3-4 shielded pair, 3-6, 3-7 skin effect, 3-4, 3-9 standing-wave ratio (SWR), 3-5 twisted pair, 3-6, 3-7 two-wire, 3-1 two-wire open line, 3-6 two-wire ribbon line, 3-7 voltage standing-wave ratio, (vswr), 3-6 waveguides, 3-6

iris, 3-20 junctions, 3-27 loop, 3-19 magic-T, 3-28, 3-30 posts, 3-20 probes, 3-18 resistive load, 3-21, 3-22 screws, 3-21 slots, 3-18, 3-19 T junction (E and H type), 3-28, 3-29 terminations, 3-20 windows, 3-18

Waveguides, 3-6 “a” dimension, 3-12 “b” dimension, 3-12 angle of incidence,  $\theta_i$ , 3-14, 3-15 angle of reflection  $(\theta_r)$ , 3-14, 3-15 arcing, 3-10 bends, 3-22 boundary conditions, 3-13 choke joint, 3-23, 3-24 circular, 3-16 cutoff frequency, 3-12, 3-15 dominant mode, 3-16 E bend, 3-22 electrolysis, 3-24 group velocity, 3-15 H bend, 3-22 joints, 3-23 metallic insulator, 3-10, 3-11 mode numbering, 3-17 mode of operation, 3-12, 3-15 plumbing, 3-22 Poynting vector, 3-14 rotating joint, 3-23, 3-24 sharp bend, 3-23 size, 3-10 transverse electric (TE), 3-17 transverse magnetic (TM), 3-17 twist, 3-23

## W

Waveguide input/output, 3-18 apertures, 3-18, 3-19 bidirectional coupler, 3-25, 3-26 cavity resonators, 3-25, 3-26, 3-27 directional coupler, 3-25, 3-26 dummy load, 3-21 duplexer, 3-31 horn, 3-21 hybrid junctions, 3-25, 3-28, 3-30 hybrid ring, 3-28, 3-31, 3-32 impedance matching, 3-19